



Set using ISO screws

CRF-160



SONY[®]
SERVICE MANUAL

TABLE OF CONTENTS

<i>Title</i>	<i>Page</i>
SECTION 1. TECHNICAL DESCRIPTION	3
1-1. Specifications	3
1-2. Technical Features	4
1-3. Circuit Description	4~6
1-4. Block Diagram	7
1-5. External View	8
1-6. Major Parts Location	8
SECTION 2. DISASSEMBLY	9
2-1. Chassis Removal	9~10
2-2. Fm Front End Block Removal	10
2-3. Sw Front End Block Removal	10~11
2-4. Cp/I-f Circuit Board Removal	11
2-5. Dc Power Supply Circuit Board Removal	12
2-6. Af Circuit Board Removal	12
2-7. Dial Scale and Dial Drum Removal	12
2-8. Ac Power Supply Circuit Board Removal	13
2-9. Bfo Block Removal	13
2-10. Dial Cord Restrunging	14~15
SECTION 3. CIRCUIT ADJUSTMENTS	16
3-1. I-f Alignment	16
3-2. Frequency Coverage and Tracking Adjustment	17~20
3-3. Adjusting Parts Locations	20~21
3-4. Voltage and Current Adjustment	21~22
3-5. Bfo Adjustment	22
SECTION 4. MOUNTING AND SCHEMATIC DIAGRAMS	23
4-1. Fm Front End Circuit Board (P1)	23
4-2. Sw2 - Sw10 Front End (P2)	24~27
4-3. Cp/I-f Circuit Board (P3)	28~30
4-4. Af Circuit Board (P4)	31
4-5. Power Supply Circuit Board (P5)	32
4-6. Jack Panel	33
4-7. Bfo Block (P6)	34
4-8. Wiring Diagram	35~36
4-9. Schematic Diagram	37~39
SECTION 5. PACKING AND EXPLODED VIEW	40
5-1. Packing	40
5-2. Exploded View	41~46
SECTION 6. ELECTRICAL PARTS LIST	47~52

SECTION 1 TECHNICAL DESCRIPTION

1-1. SPECIFICATIONS

Circuit System:	2-FET, 19-transistor, 12-diode superheterodyne	
Frequency Coverage:	FM;	87.5 – 108 MHz (3.42 – 2.78 m)
	MW;	530 – 1,605 kHz (566 – 187 m)
	LW;	150 – 400 kHz (2,000 – 750 m)
	SW1;	1.6 – 4.5 MHz (187 – 67 m)
	SW2;	4.7 – 5.3 MHz (64 – 57 m)
	SW3;	5.8 – 6.4 MHz (52 – 47 m)
	SW4;	7.0 – 7.6 MHz (43 – 39 m)
	SW5;	9.5 – 10.1 MHz (31.6 – 30 m)
	SW6;	11.6 – 12.2 MHz (26 – 24.6 m)
	SW7;	15.0 – 15.6 MHz (20 – 19.2 m)
	SW8;	17.5 – 18.1 MHz (17 – 16.5 m)
	SW9;	21.4 – 22.0 MHz (14 – 13.6 m)
	SW10;	25.5 – 26.1 MHz (11.8 – 11.5 m)
Intermediate Frequency:	FM;	10.7 MHz
	MW, LW, SW1;	455 kHz
	SW2–SW10; 1st:	1.55 – 2.25 MHz
	2nd:	455 kHz
Antenna System:	FM;	telescopic antenna or external antenna (impedance 50~300 Ω)
	MW, LW;	built-in ferrite bar antenna or external antenna (high impedance)
	SW1;	telescopic antenna or external antenna (high impedance)
	SW2–SW10;	telescopic antenna or external antenna (impedance 75 Ω)
Maximum Sensitivity:	FM;	1 μ V (0dB)
(at 50 mW output)	MW;	25.5 μ V/m (28dB/m)
(S/N 6 dB)	LW;	39.8 μ V/m (32dB/m)
	SW1;	1 μ V (0dB)
	SW2 – SW10;	1 μ V (0dB)
Selectivity:	40dB at 1,400kHz \pm 10kHz off resonance	
Power Requirement:	Six "D" size flashlight batteries 9 volts in total, or house current (ac 100V, 120V, 220V, 240V for General Export Model) (ac 120V for USA and Canada Model)	
Power Output		
at 10% distortion:	2.3 W (with ac power supply),	1.1 W (with battery)
maximum:	3.8 W (with ac power supply),	1.7 W (with battery)
Current Drain		
at zero signal:	78 mA (with ac power supply),	35 mA (with battery)
Speaker:	3 $\frac{1}{8}$ " (8cm) x 6 $\frac{1}{4}$ " (16cm), 4 Ω	
Dimensions:	13 $\frac{3}{8}$ " (W) x 10 $\frac{13}{16}$ " (H) x 5 $\frac{11}{16}$ " (D) (340mm x 275mm x 144mm)	
Weight:	15 lb 7 oz (7 kg)	

1-2. TECHNICAL FEATURES

- * High-performance portable radio receiver with thirteen bands; FM, MW, LW, SW1-SW10.
- * FET (field effect transistor) with triple-tuned passive input circuit for superior interference rejection.
- * High-sensitivity and selectivity on SW bands using double-superheterodyne front end.
- * High-fidelity af amplifier with OTL circuit.
- * Choice of three power sources; house current, battery, car battery.
- * BFO circuit for SSB signal reception.

1-3. CIRCUIT DESCRIPTION

Stage/control

Function

Fm Front End

FET mixer
Q101

Usually an fm front end consists of an rf amplifier, mixer and local oscillator as shown in Fig. 1-1.

The rf amplifier sometimes worsens the crossmodulation handling ability of the receiver when ordinary bipolar transistors are used. It is, however, difficult to eliminate the rf amplifier because its removal causes strong spurious radiation, poor sensitivity, and a poor noise figure. To solve this problem, the Model CRF-160

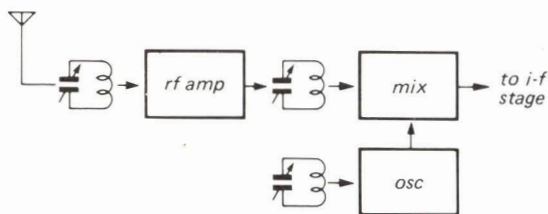

Fig. 1-1 Usual fm front end

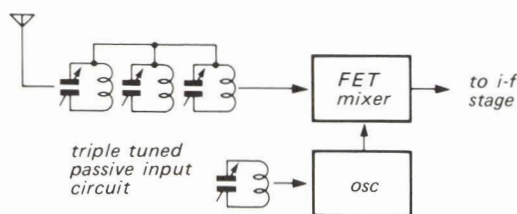

Fig. 1-2 CRF-160 fm front end

uses a low-noise junction FET for the mixer and a triple-tuned passive input circuit as shown in Fig. 1-2. The Model CRF-160 is capable of clear fm reception even in strong signal-strength areas due to the extremely superior interference-rejection characteristics of the passive input circuit.

Local oscillator,
Q102

The oscillator generates a frequency 10.7 MHz higher than the incoming signal frequency and injects the generated voltage at the source of FET mixer Q101.

Afc diode
D101

This diode is connected across the resonant circuit of the oscillator and works as a variable-capacitance diode. A dc feedback voltage from the discriminator controls the bias applied to the diode to keep the local oscillator frequency correct.

Fm i-f amplifier
Q103

Transistor Q103 amplifies the 10.7 MHz i-f signal produced by mixer Q101 and coupled to it through i-f transformer IFT F101.

Sw Front End

Double-superheterodyne

A block diagram of the sw front end is shown in Fig. 1-3. Such an arrangement effectively suppresses image signals, since the high value of the first i-f causes the desired and image signals to differ greatly in frequency. At the same time, the relatively low value of the second i-f makes it possible to obtain high amplification as well as sharp discrimination against signals differing only slightly in frequency from the desired signal.

The result is that this double-superheterodyne front end provides a combination of greater image suppression and higher adjacent channel-selectivity than can be realized in a simple superheterodyne receiver.

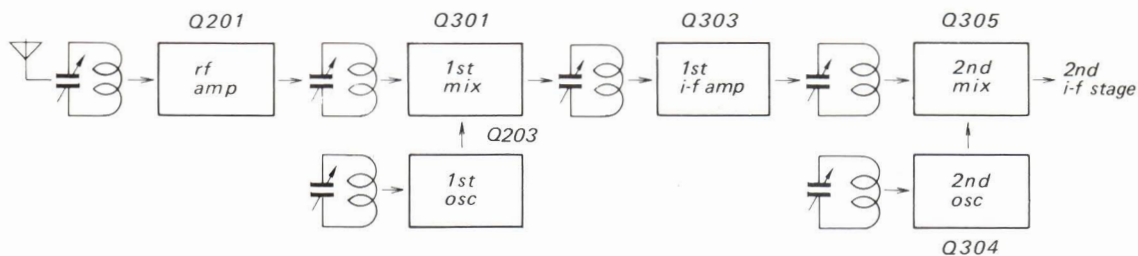

Fig. 1-3 Block diagram of the sw front end

Agc amp
Q202
D302

The agc (automatic gain control) circuit consists of transistor Q202 and diode D302. The carrier from the last stage of the i-f amplifier adds a negative agc voltage on the positively-biased base of transistor Q202 through diode D302 as shown in Fig. 1-4.

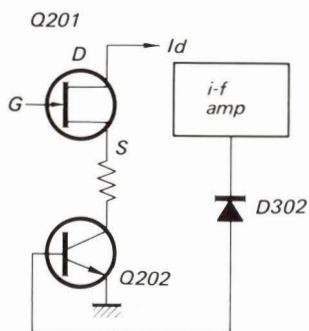

Fig. 1-4 Diagram of the agc

As the signal becomes stronger, the agc level becomes higher also. Accordingly, the collector-current of Q202 and the drain-current of Q201 decrease. If the signal is small, Q202 increases the gain of rf amplifier Q201 and the desired sensitivity is obtained as shown in Fig. 1-5. In this way, the gain is controlled automatically.

1st local oscillator
Q203

The oscillator generates a frequency 1.55 – 2.25 MHz higher than the incoming signal frequency, and injects the generated voltage at the emitter of Q301. The oscillator frequencies are fixed in each band.

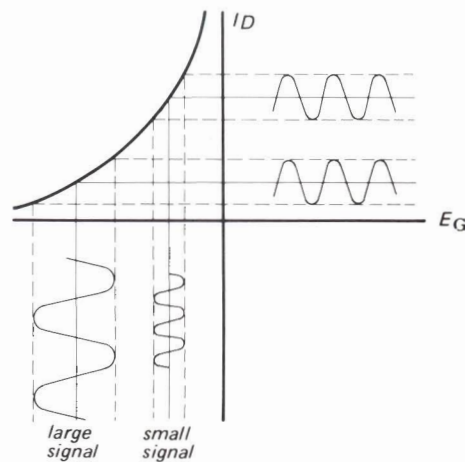

Fig. 1-5 Output waveform of the agc

I-f Strip

1st mixer
Q301

Q301 combines the signal applied to its base with the oscillator voltage (1.55 – 2.25 MHz higher than incoming signal) applied to its emitter for conversion to the 1.55 – 2.25 MHz 1st i-f.

SW 1st i-f amplifier
MW, LW, SW1 rf amplifier
Q303

Q303 amplifies four a-m signals; 1.55 – 2.25 MHz (SW2 – SW10), 520 – 1,670 kHz (MW), 145 – 410 kHz (LW) and 1.6 – 4.5 MHz (SW1).

2nd oscillator
Q304

Q304 generates a frequency 455 kHz higher than the signals that come from Q303.

Fm i-f amplifier
Q302

Q302 amplifies the 10.7 MHz fm i-f signal coupled through ceramic filters CF301 and CF302. Also, the saturation due to high base to emitter bias clips the negative peak of the ac signal voltage developed at the collector of Q302.

Limiter D301 This diode clips the positive peak of ac signal voltage developed at the collector of Q305.

Fm i-f amplifier Q305 Q305 amplifies 10.7 MHz fm i-f signal. Also, Q305 produces a 455 kHz a-m i-f signal on its collector.

A-m 2nd mixer Q305

Power Supply

The CRF-160 uses a 4-pin ac cord for its power supply and has a power-in jack for a house current 100V, 120V, 220V and 240V (for USA and Canada model 120V only). However, by using the SONY DCC-2A Car Battery Cord or standard flashlight batteries (six size "D" cells), the CRF-160 can be operated away from an ac power outlet. Though diode D502 prevents a reverse current flow through the batteries when using a house current or car battery, it is better to remove the flashlight batteries if they will not be used for a while.

Selectivity Selector

The stage selectivity is obtained by using a ceramic filter (CF304) as a frequency-selective bypass centered at 455 kHz. This gives transistor Q306 a high gain at 455 kHz by preventing emitter degeneration of the signal at this frequency. By connecting capacitor C378 in parallel with filter CF304 (See Fig. 1-6), the BROAD selectivity bandwidth is obtained. When the SHARP position is set, the bandwidth becomes narrow. However, greater sensitivity with less noise is obtained and a weak signal can easily be heard.

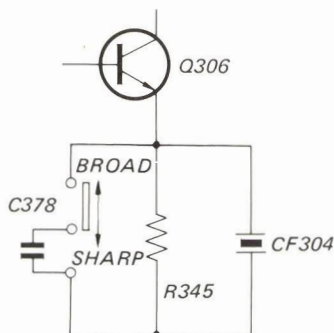

Fig. 1-6 Selectivity selection circuit

Audio Amplifier

VOLUME control VR601 The level of signal applied to the power amplifier is determined by the setting of VR601.

Amplifier Q401 Transistor Q401 amplifies the audio signal supplied by VOLUME control VR601.

Audio driver Q402, Q403 These direct-coupled stages amplify the audio signal supplied by TONE control VR602.

Power amplifier Q404, Q405 This stage uses an OTL (output transformerless) push-pull class-B amplifier. Thermistors Th401 and Th402 temperature-compensate the base bias of Q404 and Q405. Negative feedback from the output of Q404 and Q405 to the emitter of Q403 improves the frequency response and reduces distortion.

BFO (beat frequency oscillator) Circuit

To reproduce a SSB (single sideband) signal, this oscillator generates a frequency between 452 kHz and 458 kHz and injects the generated voltage into the base of transistor Q307. The BFO frequency is changed by varying the base bias of Q01 with VR02 (BFO PITCH control). The BFO center frequency is set with L01, and the BFO control range is set with VR02 (1 kΩ semi-fixed resistor). Thermistor Th01 compensates this oscillator for frequency drift caused by temperature variations.

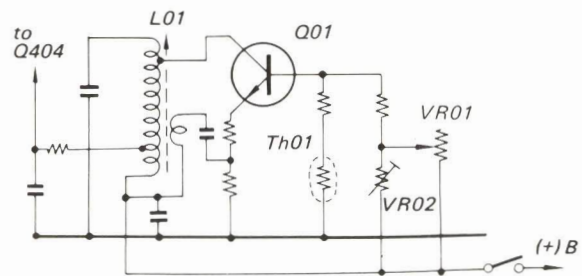
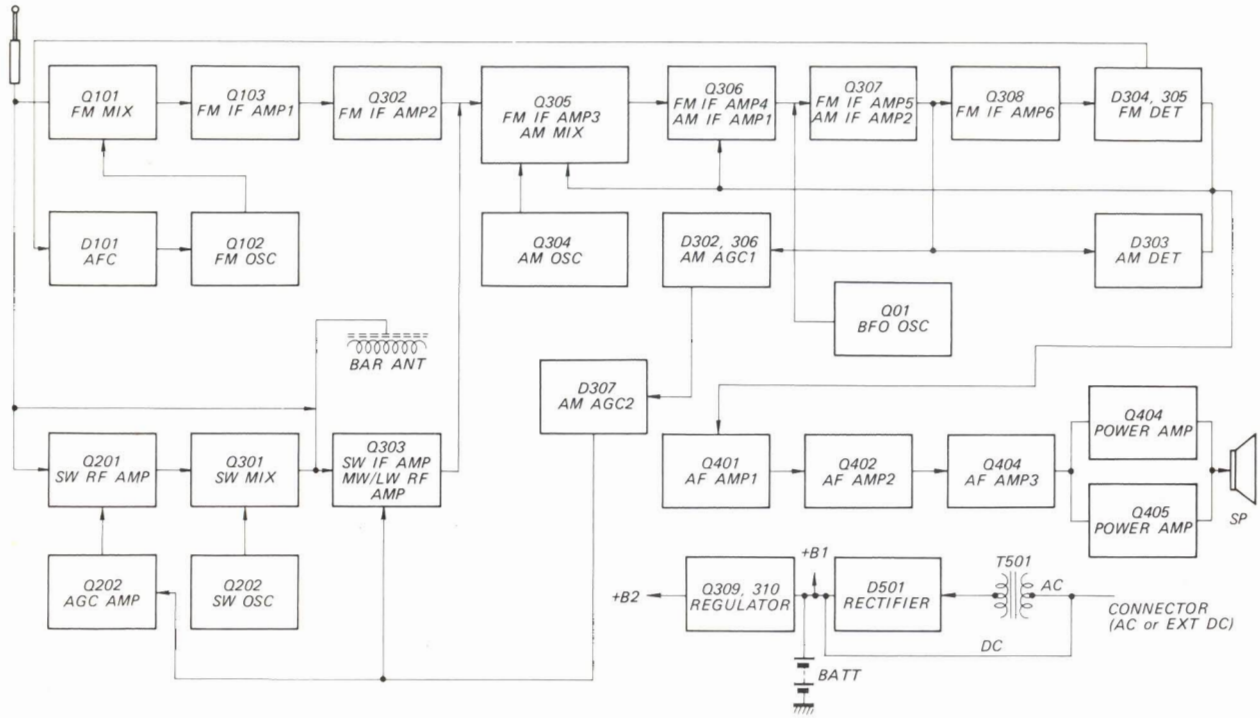

Fig. 1-7 BFO circuit

1-4. BLOCK DIAGRAM



Hardware Nomenclature

P - Pan Head Screw		SC - Set Screw	
PS - Pan Head Screw with Spring Washer		E - Retaining Ring (E Washer)	
K - Flat Countersunk Head Screw		W - Washer	
B - Binding Head Screw		SW - Spring Washer	
RK - Oval Countersunk Head Screw		LW - Lock Washer	
T - Truss Head Screw		N - Nut	
R - Round Head Screw			
F - Flat Illister Head Screw			

Example

Type of Slot:

⊕ P 3x10

Length in mm (L):

Diameter in mm (D):

Type of Head:

1-5. EXTERNAL VIEW

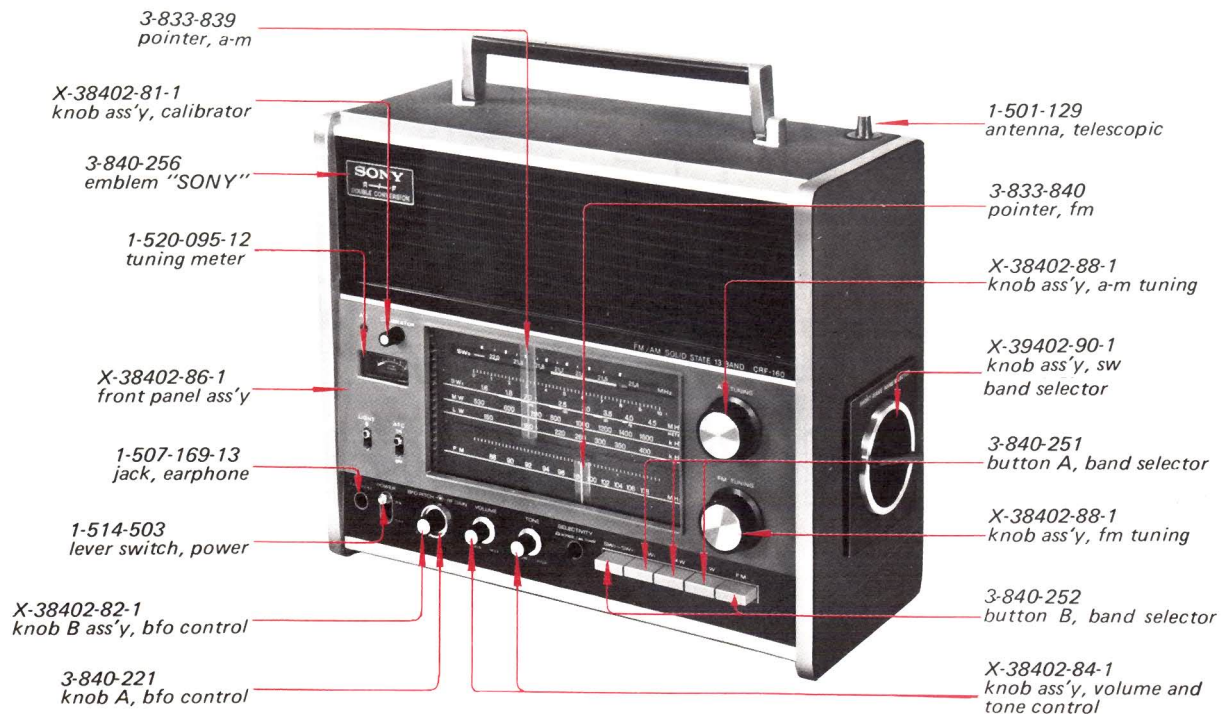

Fig. 1-8

1-6. MAJOR PARTS LOCATION

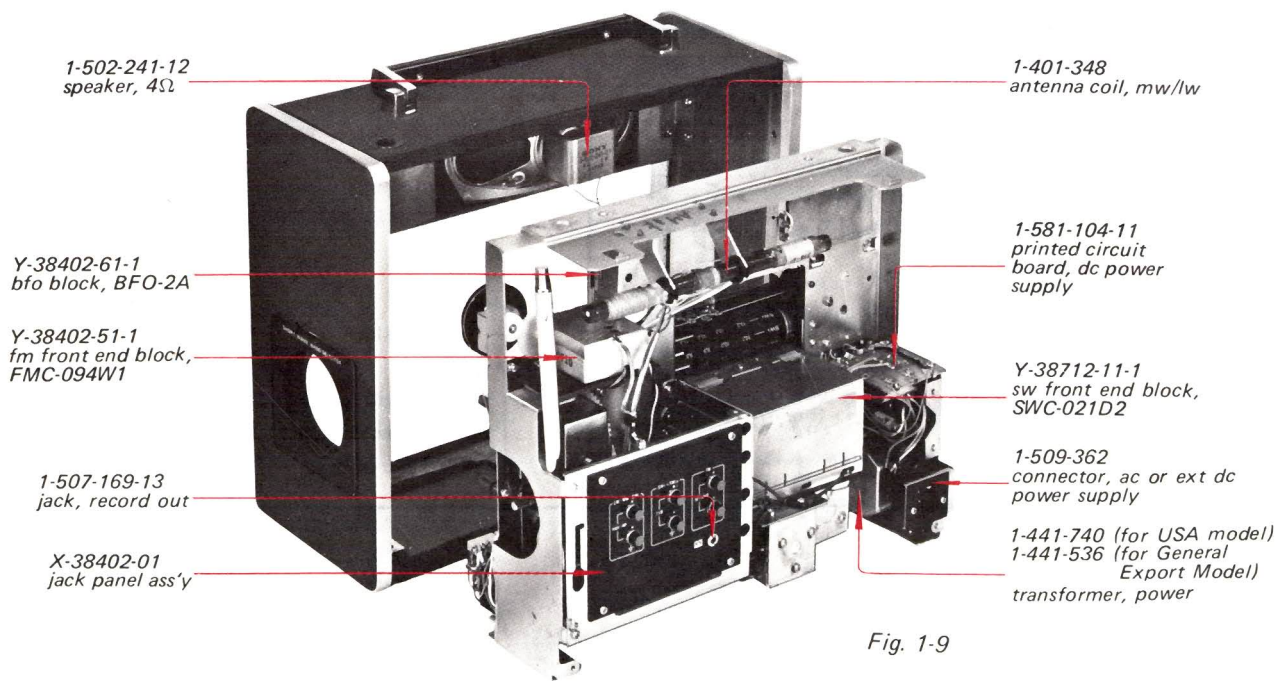

Fig. 1-9

SECTION 2 DISASSEMBLY

2-1. CHASSIS REMOVAL

1. Pull off the six knobs shown in Fig. 2-1.

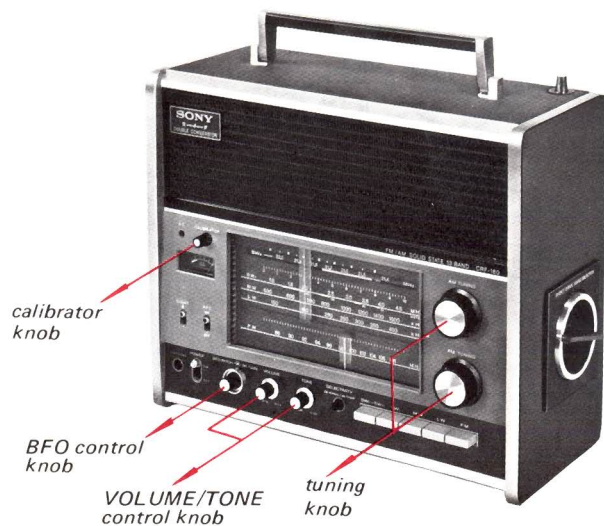

Fig. 2-1

2. Remove the battery lid and take out batteries and ac cord.
3. Remove the three screws shown in Fig. 2-2.

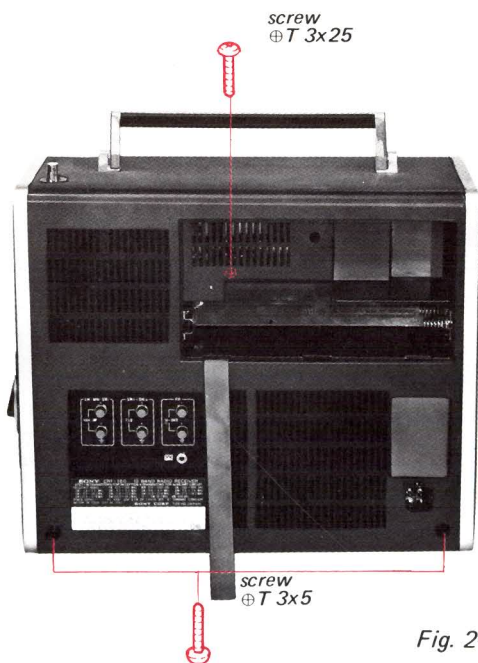

Fig. 2-2

4. Remove the six screws marked Δ which fasten the front panel to the chassis in Fig. 2-3.
5. Loosen a screw marked $*$ and remove the telescopic antenna.
6. Now, the front panel is removable as shown in Fig. 2-4.
7. Remove the three screws and two rubber feet as shown in Fig. 2-4.

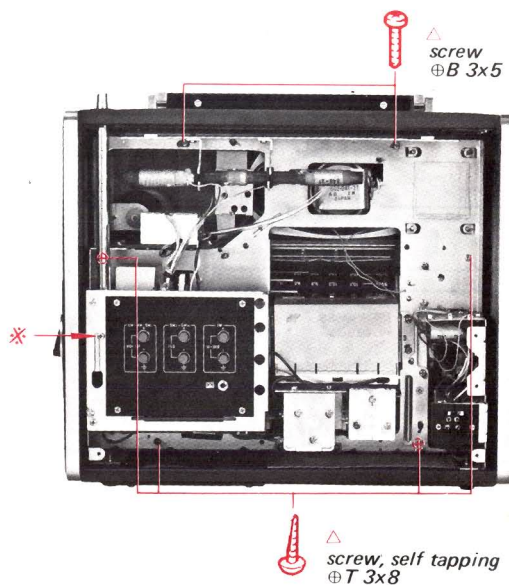

Fig. 2-3

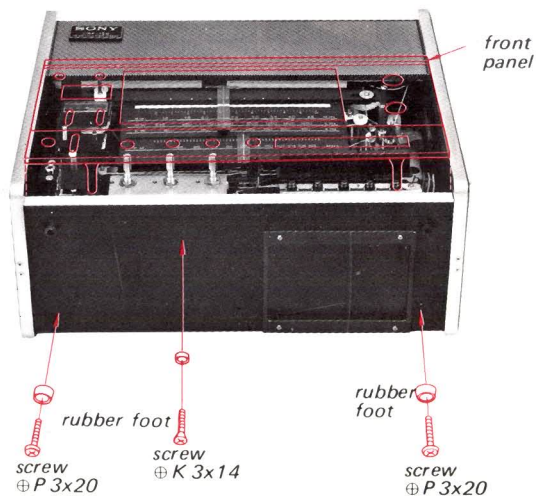

Fig. 2-4

8. Loosen the three set screws and pull off the sw band selector knob as shown in Fig. 2-5.
9. Now, the chassis is removable as shown in Fig. 2-6.

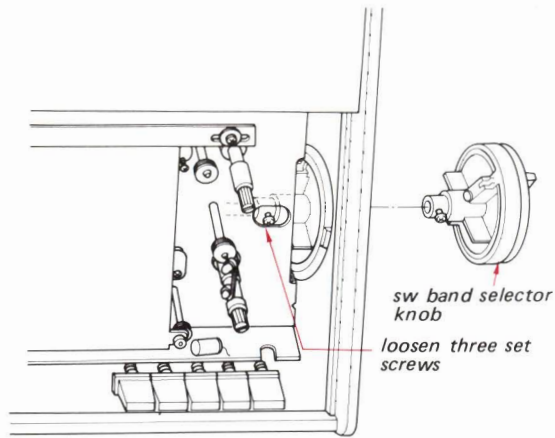

Fig. 2-5

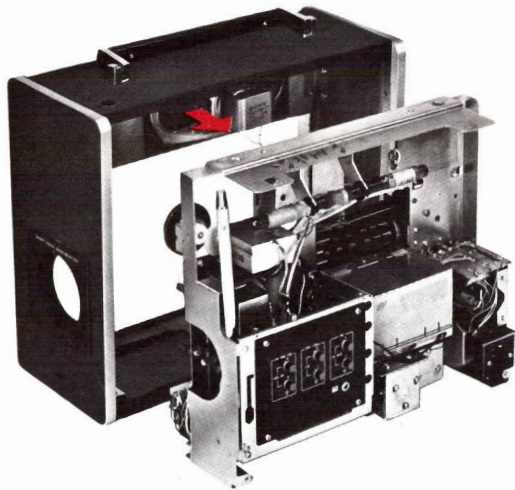

Fig. 2-6

2-2. FM FRONT END BLOCK REMOVAL

1. Remove the chassis.
2. Remove the seven screws marked \circ and \triangle in Fig. 2-7.
3. Remove the two screws marked \star .
4. Remove the screw marked \odot .
5. Unsolder the two soldered portions on the shield cover marked \square .
6. Take out the shield cover and fm front end circuit board as illustrated in Fig. 2-7.

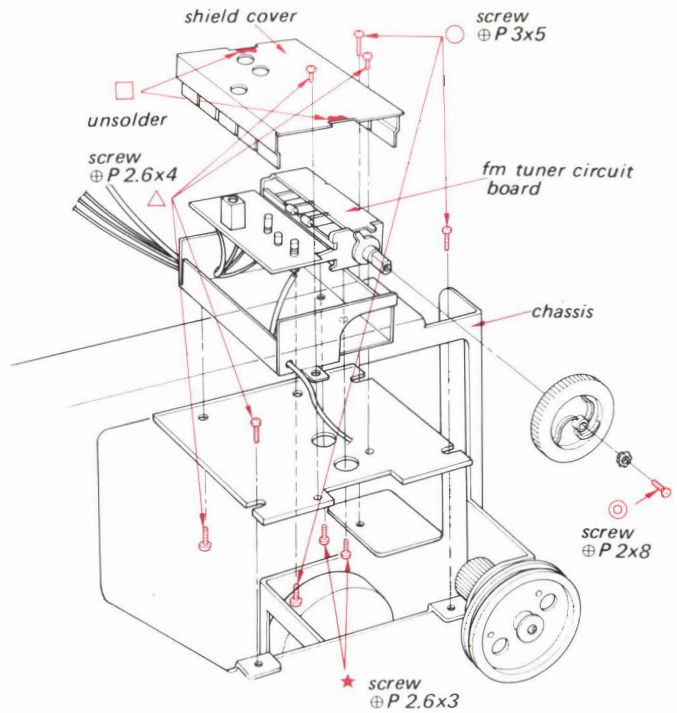

Fig. 2-7

2-3. SW FRONT END BLOCK REMOVAL

1. Remove the chassis.
2. Unsolder the ten lead wires shown in Fig. 2-8.

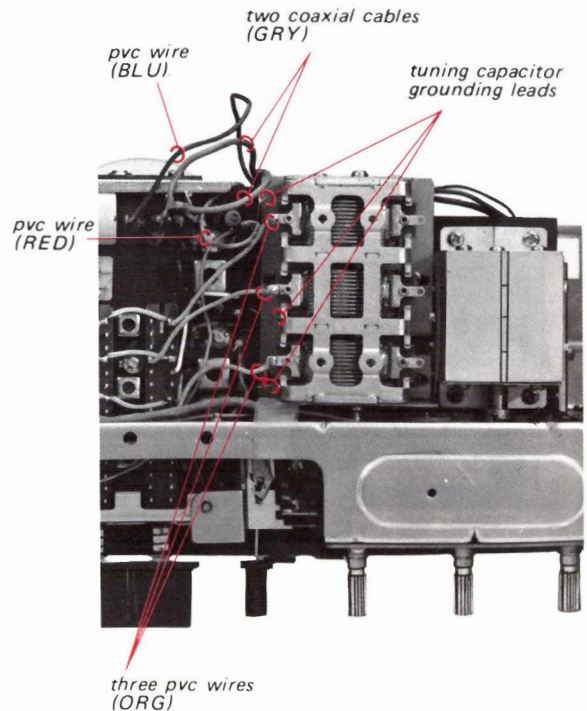

Fig. 2-8

3. Remove the six screws and the shield cover as shown in Fig. 2-9 and unsolder the two lead wires.
4. Loosen the two set screws marked \odot .
5. Now, sw tuner block is removable in the direction shown by the arrow.

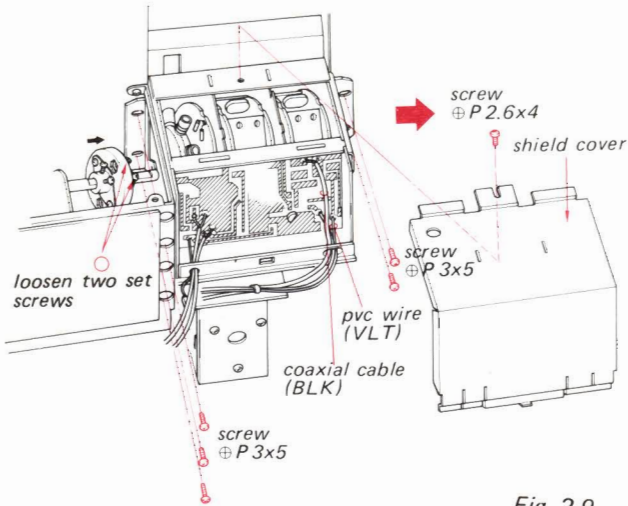

Fig. 2-9

2-4. CP/IF CIRCUIT BOARD REMOVAL

1. Unsolder the same ten lead wires in Fig. 2-8 as sw tuner removal.
2. Unsolder the six lead wires at ferrite bar antenna as shown in Fig. 2-10.

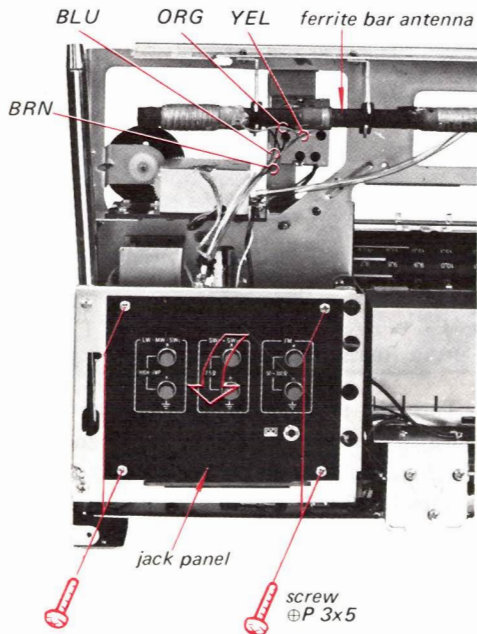

Fig. 2-10

3. Remove the four screws at the jack panel as illustrated in Fig. 2-10 and unsolder the nine lead wires shown in Fig. 2-11.
4. Remove the three screws shown in Fig. 2-12.
5. Unsolder the three lead wires.
6. Loosen the four lead wires from the lead wire holding lug.
7. Slide off the cp/i-f circuit board in the direction shown by the arrow in Fig. 2-12.

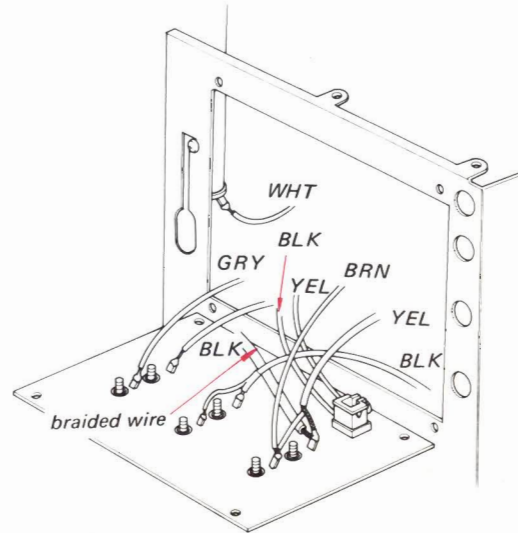

Fig. 2-11

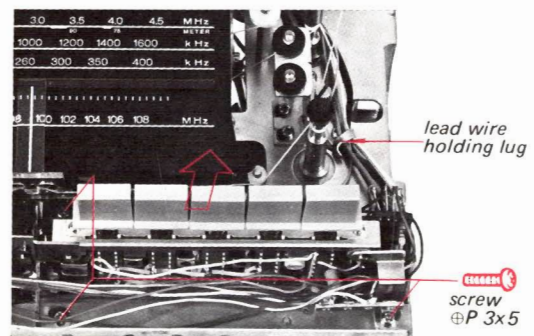

Fig. 2-12

2-5. DC POWER SUPPLY CIRCUIT BOARD REMOVAL

1. Remove the two screws shown in Fig. 2-13.
2. Turn the circuit board in the direction shown by the arrow.

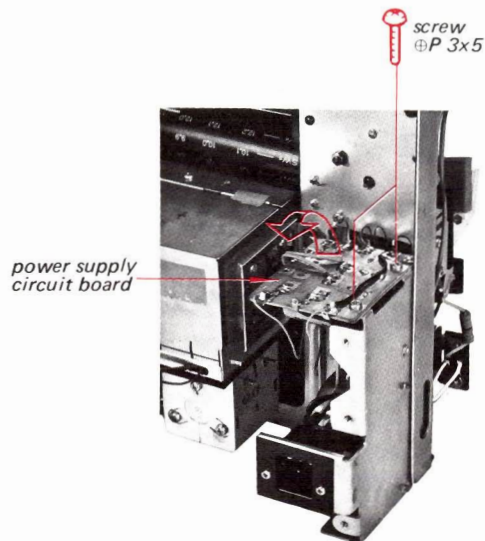

Fig. 2-13

2-6. AF CIRCUIT BOARD REMOVAL

1. Remove the five screws shown in Fig. 2-14.
2. Remove the circuit board in the direction shown by the arrow.

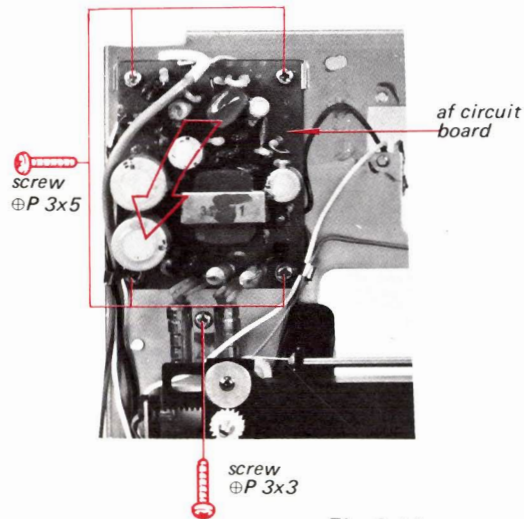

Fig. 2-14

2-7. DIAL SCALE AND DIAL DRUM REMOVAL

1. Remove the chassis.
2. Remove the four screws shown in Fig. 2-15.
3. Release the pointers from dial cords.

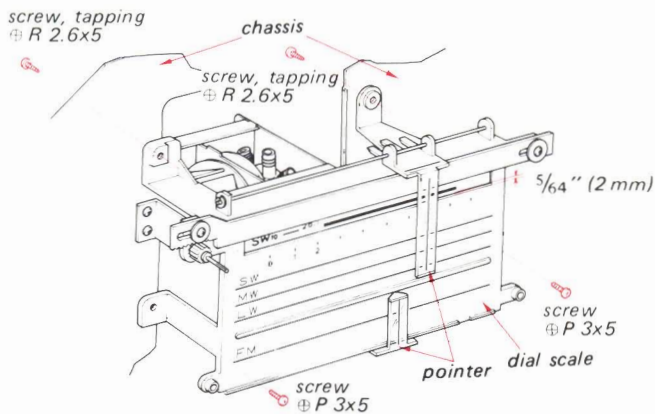

Fig. 2-15

4. Remove the dial scale.
5. Remove the drum holder A by removing the two screws marked ⊙ in Fig. 2-16.
6. Release the two screws marked ☆ in Fig. 2-16.
7. Pull the dial drum towards you.

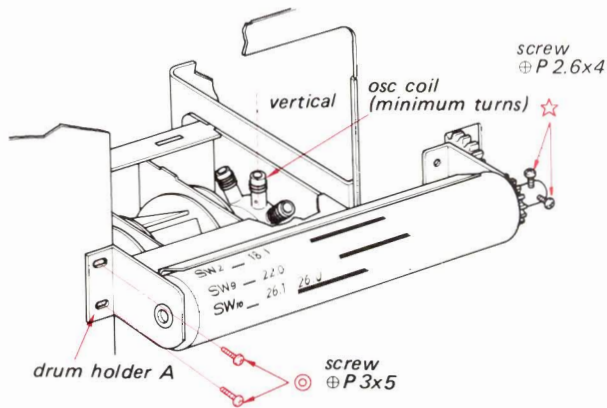

Fig. 2-16

Dial Drum Reassembly

1. Turn the sw band selector so that the osc coil which has the minimum turns comes to the vertical position as shown in Fig. 2-16.
2. Attach the dial drum to the drum holders setting the two screws marked ⊙ in Fig. 2-16.
3. Set the dial scale.
4. Turn the dial drum so that the drum indicates SW10 and the distance between the dial scale and the line on the drum becomes 5/64 inches (2mm) as shown in Fig. 2-15.
5. Fasten the two screws marked ☆ in Fig. 2-16.

2-8. AC POWER SUPPLY CIRCUIT BOARD REMOVAL

1. Remove the six screws shown in Fig. 2-17 and pull the power supply block in the direction shown by the arrow.
2. Remove the screw shown in Fig. 2-18.
3. Now, the ac power supply circuit board is removable.

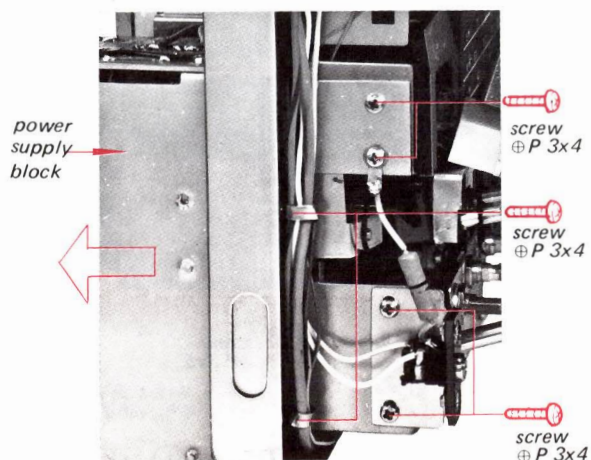

Fig. 2-17

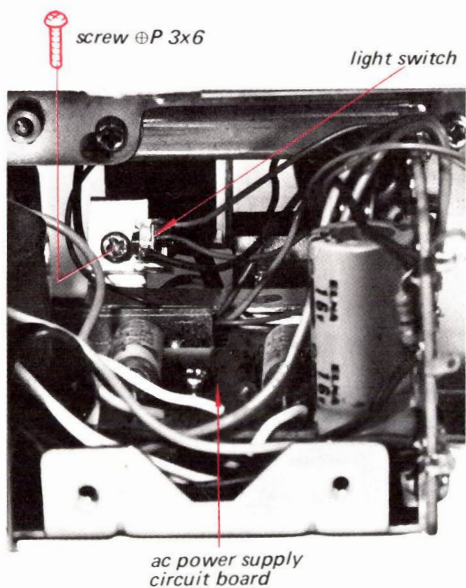

Fig. 2-18

2-9. BFO BLOCK REMOVAL

1. Remove the step screw.
2. Remove the bfo block.

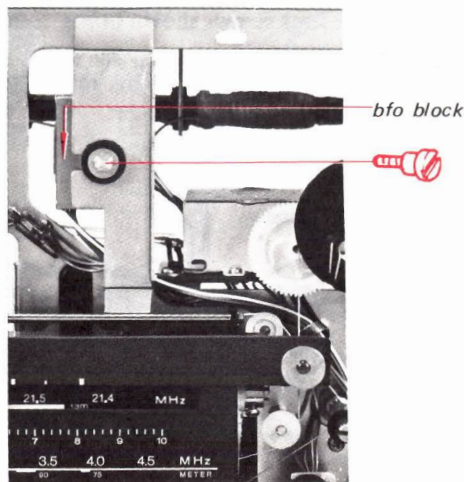

Fig. 2-19

2-10. DIAL CORD RESTRINGING

Preparation

1. Remove the chassis.
2. Remove the four screws shown in Fig. 2-20 and take out the dial scale.
3. Remove the volume holder by removing the two screws as shown in Fig. 2-21.

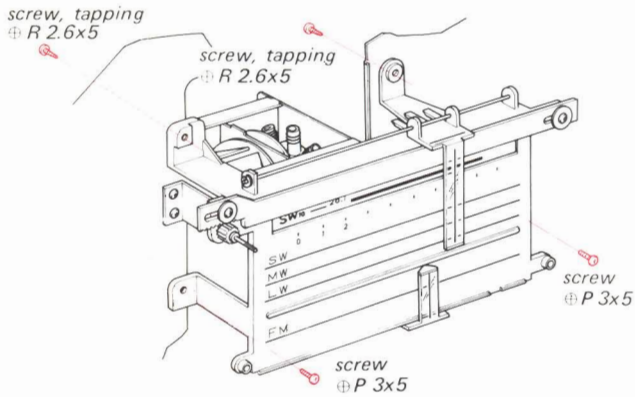

Fig. 2-20

4. Rotate the driving pulley for a-m bands fully clockwise to its minimum capacitance position as shown in Fig. 2-22.
5. Rotate the driving pulley for fm band fully counterclockwise to its minimum capacitance position as shown in Fig. 2-23.

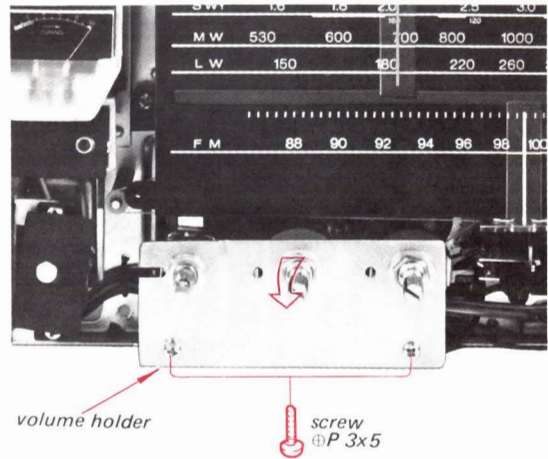

Fig. 2-21

1. A-m Tuning Capacitor Driving Cord

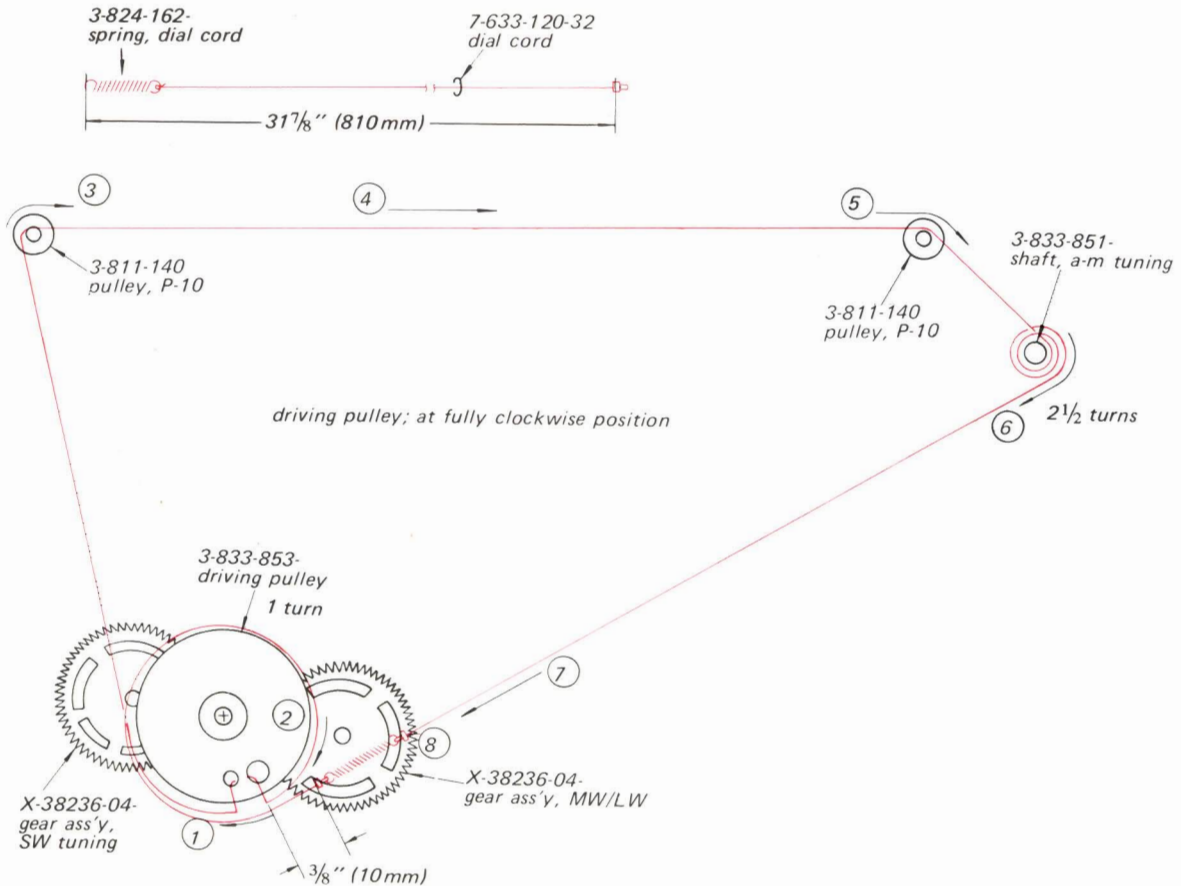

Fig. 2-22

2. Fm Tuning Capacitor Driving Cord

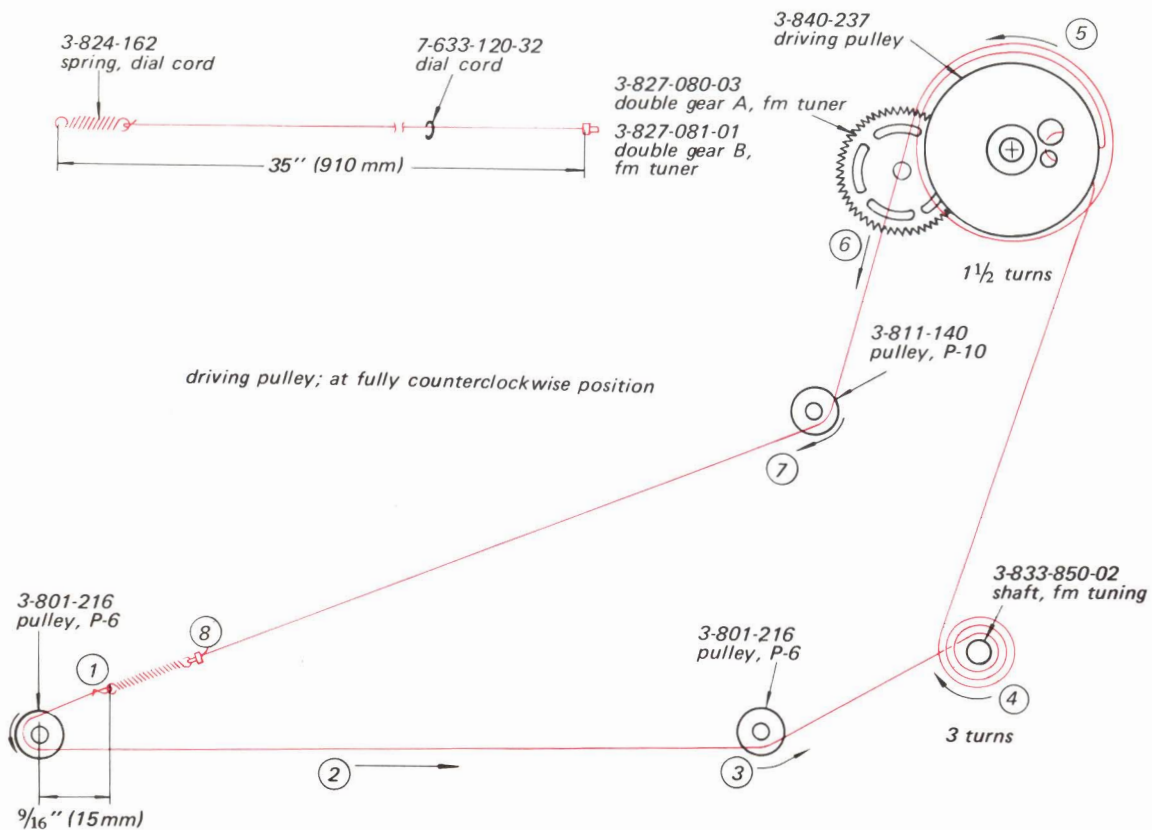

Fig. 2-23

3. Pointer Setting

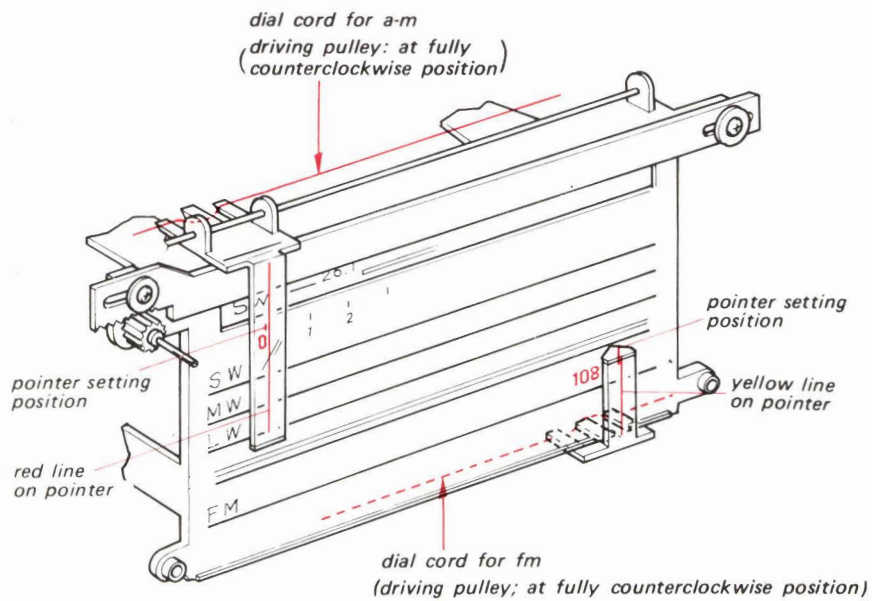

Fig. 2-24

SECTION 3 CIRCUIT ADJUSTMENTS

3-1. IF ALIGNMENT

Test Equipment/Tools Required: 10.7 MHz Sweep Generator
 Rf signal generator (for fm and a-m)
 Oscilloscope
 VTVM
 Loop antenna
 Screwdriver for alignment

1. FM IF ALIGNMENT

Preparation: Band selector: FM
 AFC: OFF
 Selectivity: SHARP

Sweep Generator Coupling	Sweep Generator Frequency	Oscilloscope Connection	Adjust	Remarks
Direct connection to EXT. ANT. 300Ω (See Fig. 3-1.)	10.7 MHz	record out jack	IFT F101 IFT F301 IFT F302 IFT F303 IFT F304	Adjust for maximum amplitude and symmetrical "S" curve on the scope. (See Fig. 3-2.) Ant. Switch: EXT. ANT.

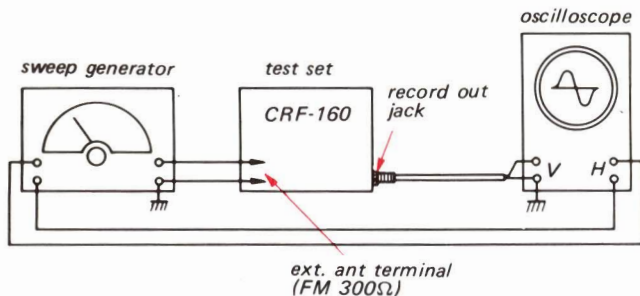

Fig. 3-1 Fm i-f alignment setup

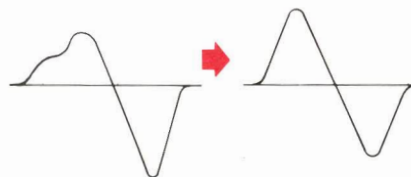

Fig. 3-2 "S" curve on oscilloscope

2. AM IF ALIGNMENT

Preparation: Band selector: MW
 Tuning knob: fully clockwise position

Rf Signal Generator Coupling	Rf Signal Generator Frequency	VTVM Connection	Adjust	Remarks
Loop antenna (See Fig. 3-3.)	455 kHz (1 kHz 30% a-m modulated)	Earphone jack with 8Ω load resistor in parallel	IFT A301	Adjust for maximum meter reading.

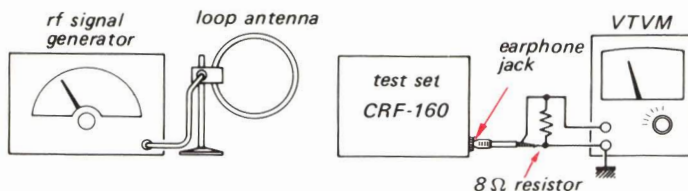

Fig. 3-3 A-m i-f alignment, MW/LW frequency coverage and tracking adjustment setup

3-2. FREQUENCY COVERAGE AND TRACKING ADJUSTMENT

Preparation: VTVM connection: To earphone jack with 8Ω load resistor in parallel

Modulation: FM 400 Hz ± 22.5 kHz frequency-modulated signal

AM 1 kHz 30% amplitude-modulated signal

AFC: OFF

Selectivity: SHARP

Note: Fm frequency coverage is changed by adjusting osc coil (L104) and osc trimmer (CT1-4) with the intended frequency signal from the rf signal generator.

Adjustment	Rf Signal Generator Coupling	Rf Signal Generator Frequency	Receiver Dial Setting	Adjust	Remarks
FM Frequency Coverage	Direct connection to ext. ant. terminal (FM 300Ω) See Fig. 3-4.	86.5 MHz	Fully left	FM osc coil L104	Band Selector: FM Ant Switch: EXT Adjust for maximum meter reading.
		109.5 MHz	Fully right	FM osc trimmer CT1-4	
FM Tracking	The special test equipment required for this adjustment makes this strictly a factory adjustment.				
MW Frequency Coverage	Loop antenna See Fig. 3-3.	523 kHz	Fully left	MW osc coil L312	Band Selector: MW Adjust for maximum meter reading.
MW Tracking		1,660 kHz	Fully right	MW osc trimmer CT309	
		620 kHz	Tune to 620 kHz signal	MW ant coil L304-1 MW rf coil L308	
		1,400 kHz	Tune to 1,400 kHz signal	MW ant trimmer CT301-2 MW rf trimmer CT305	
LW Frequency Coverage	- ditto -	145 kHz	Fully left	LW osc coil L313	Band Selector: LW Adjust for maximum meter reading.
LW Tracking		410 kHz	Fully right	LW osc trimmer CT310	
		160 kHz	Tune to 160 kHz	LW ant coil L304-2 LW rf coil L309	
		350 kHz	Tune to 350 kHz	LW ant trimmer CT301-3 LW rf trimmer CT306	
SW1 Frequency Coverage	Direct connection to ext. ant. terminal See Fig. 3-5.	1.55 MHz	Fully left	SW1 osc coil L311	Band Selector: SW1 Unsolder a blue lead shown in Fig. 3-6. Adjust for maximum meter reading.
SW1 Tracking		4.55 MHz	Fully right	SW1 osc trimmer CT308	
		1.8 MHz	Tune to 1.8 MHz	SW1 ant coil L303 SW1 rf coil L307	
		4.0 MHz	Tune to 4.0 MHz	SW1 ant trimmer CT301-1 SW1 rf trimmer CT304	

Adjustment	Rf Signal Generator Coupling	Rf Signal Generator Frequency	Receiver Dial Setting	Adjust	Remarks
SW2-SW10 1st IF Frequency Coverage	To the base of Q301 through a capacitor 0.01 - 0.04 μ F See Fig. 3-7 and Fig. 3-8.	1.55 MHz	Fully left	SW2-SW10, 2nd osc coil L310	Band Selector: SW2 Adjust for maximum meter reading.
		2.25 MHz	Fully left	SW2-SW10, 2nd osc trimmer CT307	
SW2-SW10 1st IF Tracking		1.7 MHz	Tune to 1.7 MHz signal	SW2-SW10, 1st i-f coil L302, L306	
		2.1 MHz	Tune to 2.1 MHz	SW2-SW10, 1st i-f trimmer CT302, CT303	
SW2 Frequency Coverage	To the SW2-SW10 ext. ant. terminal through a dummy ant. See Fig. 3-9. and Fig. 3-10.	4.65 MHz	Fully left	SW2 1st osc coil L207	Band Selector: SW2 Unsolder a violet lead shown in Fig. 3-10. Adjust for maximum meter reading.
SW2 Tracking		4.8 MHz	Tune to 4.8 MHz signal	SW2-SW4 ant coil L201 rf coil L204	
		5.2 MHz	Tune to 5.2 MHz signal	SW2 ant trimmer CT201 SW2 rf trimmer CT210	
SW3 Frequency Coverage	- ditto -	5.75 MHz	Fully left	SW3 1st osc coil L208	Band Selector: SW3 Adjust for maximum meter reading.
SW3 Tracking		6.3 MHz	Tune to 6.3 MHz	SW3 ant trimmer CT202 SW3 rf trimmer CT211	
SW4 Frequency Coverage	- ditto -	6.95 MHz	Fully left	SW4 1st osc coil L209	Band Selector: SW4 Adjust for maximum meter reading.
SW4 Tracking		7.5 MHz	Tune to 7.5 MHz	SW4 ant trimmer CT203 SW4 rf trimmer CT212	
SW5 Frequency Coverage	- ditto -	9.45 MHz	Fully left	SW5 1st osc coil L210	Band Selector: SW5 Adjust for maximum meter reading.
		9.6 MHz	Tune to 9.6 MHz signal	SW5-SW7 ant coil L202 rf coil L205	
SW5 Tracking		10.0 MHz	Tune to 10.0 MHz signal	SW5 ant trimmer CT204 SW5 rf trimmer CT213	
SW6 Frequency Coverage	- ditto -	11.55 MHz	Fully left	SW6 1st osc coil L211	Band Selector: SW6 Adjust for maximum meter reading.
SW6 Tracking		12.1 MHz	Tune to 12.1 MHz signal	SW6 ant trimmer CT205 SW6 rf trimmer CT214	

Adjustment	Rf Signal Generator Coupling	Rf Signal Generator Frequency	Receiver Dial Setting	Adjust	Remarks
SW7 Frequency Coverage	- ditto -	14.95 MHz	Fully left	SW7 1st osc coil L212	Band Selector: SW7 Adjust for maximum meter reading.
SW7 Tracking		15.5 MHz	Tune to 15.5 MHz signal	SW7 ant trimmer CT206 SW7 rf trimmer CT215	
SW8 Frequency Coverage	- ditto -	17.45 MHz	Fully left	SW8 1st osc coil L213	Band Selector: SW8 Adjust for maximum meter reading.
SW8 Tracking		17.6 MHz	Tune to 17.6 MHz signal	SW8 - SW10 and coil L203 rf coil L206	
		18.0 MHz	Tune to 18.0 MHz signal	SW8 ant trimmer CT207 SW8 rf trimmer CT216	
SW9 Frequency Coverage	- ditto -	21.35 MHz	Fully left	SW9 1st osc coil L214	Band Selector: SW9 Adjust for maximum meter reading.
SW9 Tracking		21.9 MHz	Tune to 21.9 MHz	SW9 ant trimmer CT208 SW9 rf trimmer CT217	
SW10 Frequency Coverage	- ditto -	25.45 MHz	Fully left	SW10 1st osc coil L215	Band Selector: SW10 Adjust for maximum meter reading.
SW10 Tracking		26.0 MHz	Tune to 26.0 MHz	SW10 ant trimmer CT209 SW10 rf trimmer CT218	

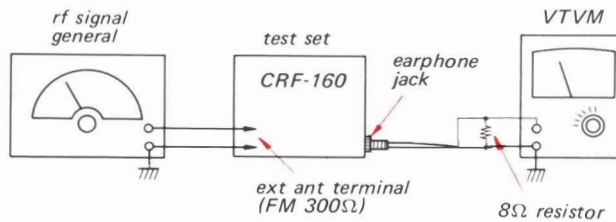

Fig. 3-4 Fm frequency coverage and tracking adjustment setup

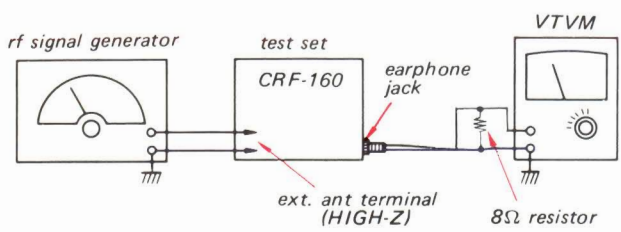

Fig. 3-5 SW1 frequency coverage and tracking adjustment setup

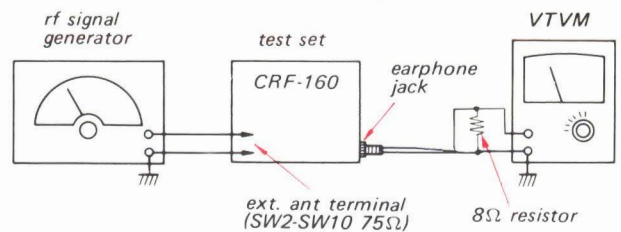

Fig. 3-9 SW2-SW10 frequency coverage and tracking adjustment setup

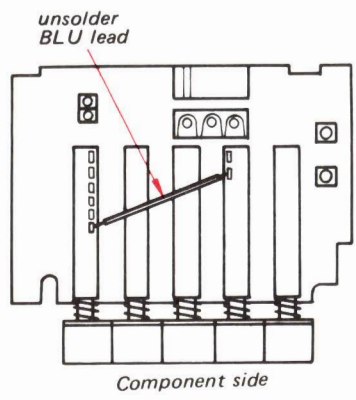

Fig. 3-6 Blue lead on cp circuit board

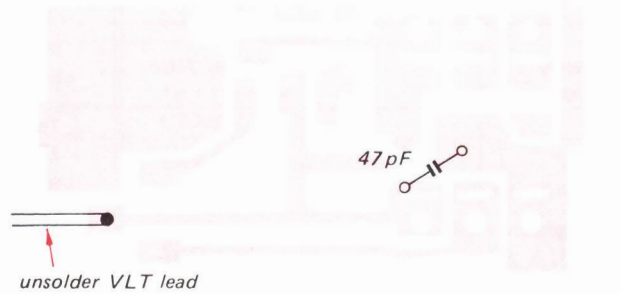

Fig. 3-10 Dummy antenna 47 pF on sw front end

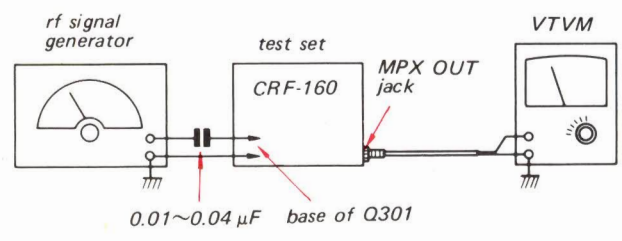

Fig. 3-7 SW2-SW10 1st i-f frequency coverage and tracking adjustment setup

3-3. ADJUSTING PARTS LOCATIONS

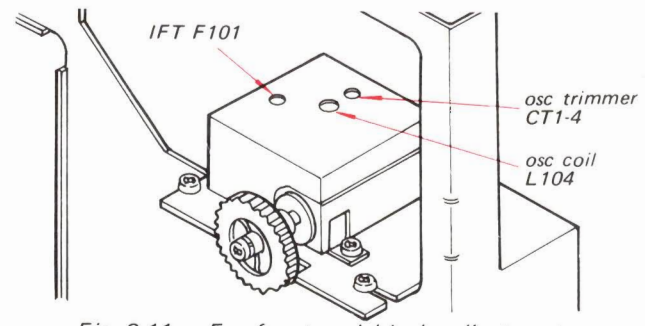

Fig. 3-11 Fm front end block adjustments on fm front end block

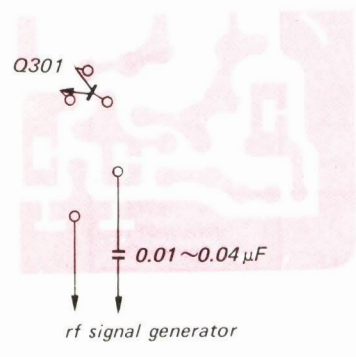

Fig. 3-8 Signal generator connection

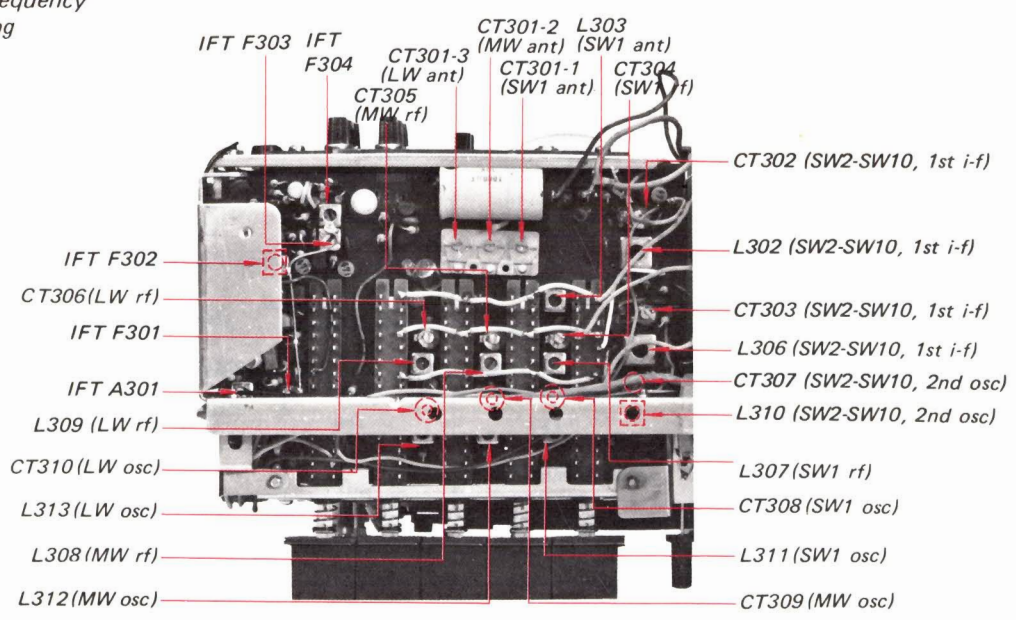

Fig. 3-12 Cp/i-f circuit board adjustments

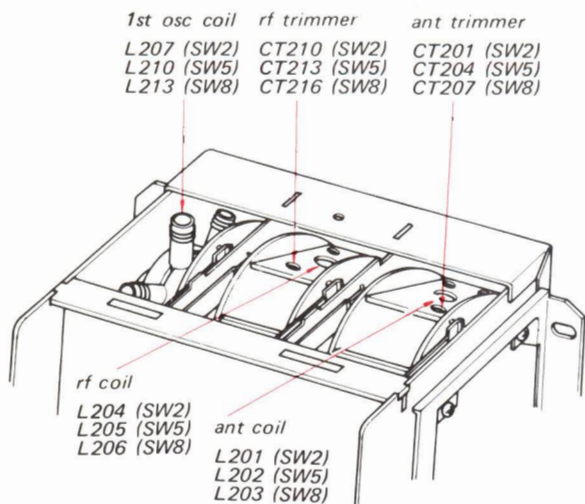

Fig. 3-13 Adjusting parts for SW2, SW5, SW8

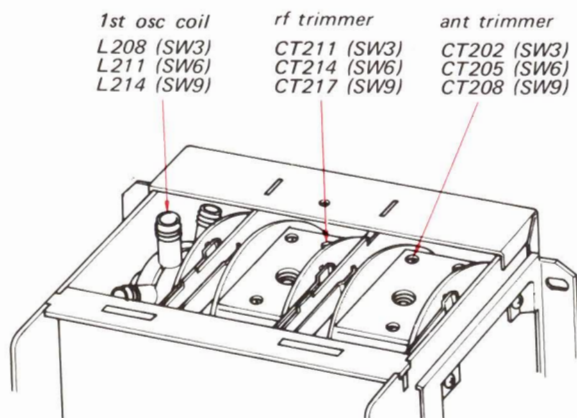

Fig. 3-14 Adjusting parts for SW3, SW6, SW9

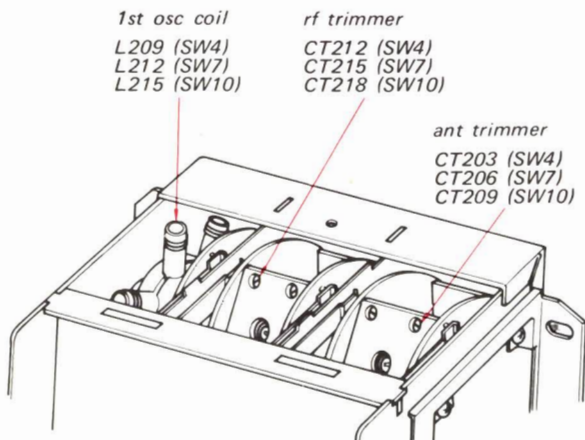

Fig. 3-15 Adjusting parts for SW4, SW7, SW10

3-4. VOLTAGE AND CURRENT ADJUSTMENT

1. Regulator Voltage

Parts to be selected: R371
 Band selector: MW
 Power requirement: ac
 Adjustment: R371 must be selected to obtain 4.5V at emitter of Q309.

R371:	¼W carbon resistor
1-240-000	510Ω
1-240-000	560Ω
1-240-000	620Ω
1-240-000	680Ω
1-240-000	750Ω

2. A-m I-f Current

Parts to be selected: R338
 Band selector: MW
 Power requirement: ac
 Adjustment: R338 must be selected to obtain 0.27V at emitter of Q306.

R338:	¼W carbon resistor
1-240-520	91 kΩ
1-240-521	100 kΩ
1-240-522	110 kΩ
1-240-523	120 kΩ
1-240-524	130 kΩ
1-240-525	150 kΩ

3. Tuning Meter Calibration (For A-m Tuning)

Parts to be selected: R342
 Band selector: MW
 Power requirement: ac
 Adjustment: R342 must be selected so that the pointer of the tuning meter shows between 0 and 1.5 when no radio signal is received.

R342:	¼W carbon resistor
1-240-473	1 kΩ
1-240-475	1.2 kΩ
1-240-479	1.8 kΩ
1-240-480	2 kΩ

4. Tuning Meter Calibration (For Fm Tuning)

Parts to be selected: R343

Band selector: FM

Power requirement: ac

Adjustment: R343 must be selected so that the pointer of the tuning meter shows between 0 and 1.5 when no radio signal is received.

R343:	¼W carbon resistor
1-240-470	750Ω
1-240-471	820Ω
1-240-472	910Ω
1-240-473	1 kΩ
1-240-475	1.2 kΩ

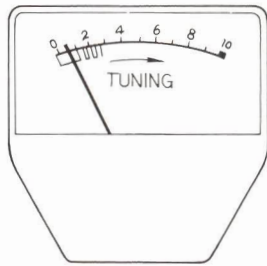

Fig. 3-16 Tuning meter

3-5. BFO ADJUSTMENT

Test Equipments/Tools Required:

- * Rf signal generator
- * Loop antenna
- * Screwdriver for alignment

Preparation:

Setup: See Fig. 3-17.

Rf signal: 455 kHz unmodulated signal

Band selector: MW

BFO PITCH control knob:
mechanical mid position

BFO-ON/MGC control knob:
mechanical mid position

Adjustment:

Adjust L01 to obtain zero beat.

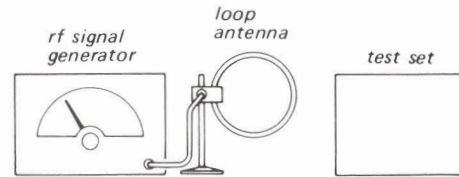

Fig. 3-17 BFO adjustment setup

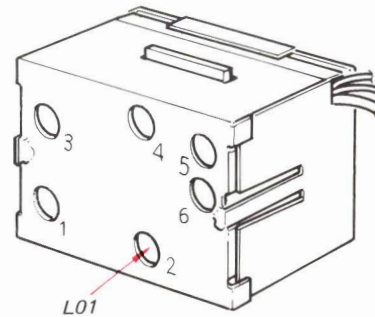
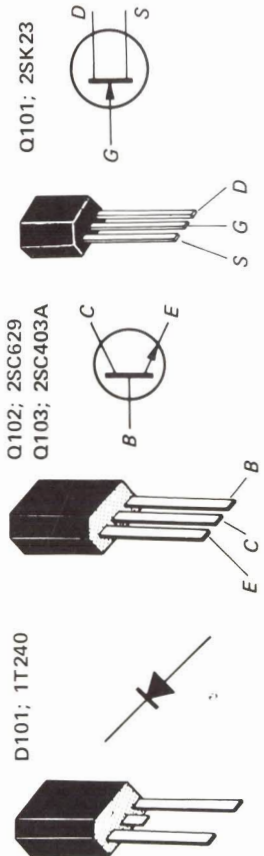
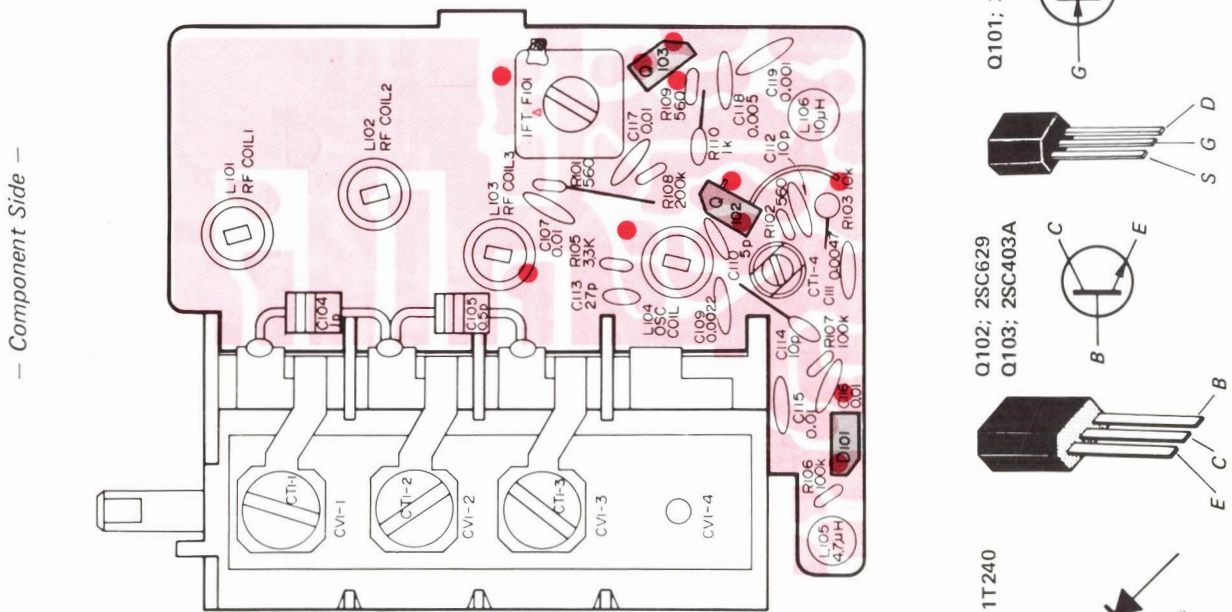
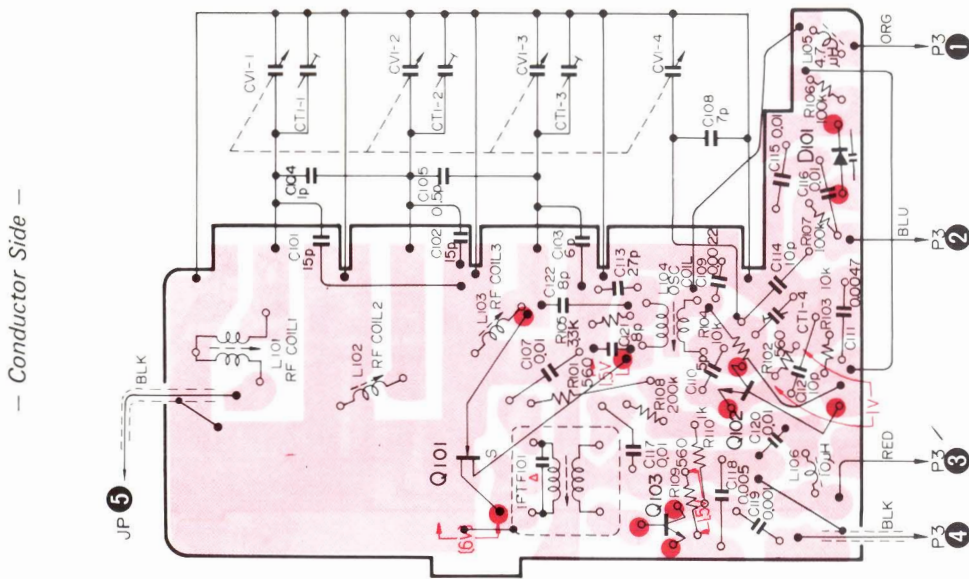

Fig. 3-18 Adjusting parts location

SECTION 4
MOUNTING AND SCHEMATIC DIAGRAMS

4-1. FM FRONT END CIRCUIT BOARD (P1)



Note: 1. The following parts are mounted on the conductor side: C101, C102, C103, C108, C120, C121, C122, R104 and Q101.
2. Printed circuit board: Part No. I-538-793-12

4-2. SW2-SW10 FRONT END (P2)

— Conductor Side —

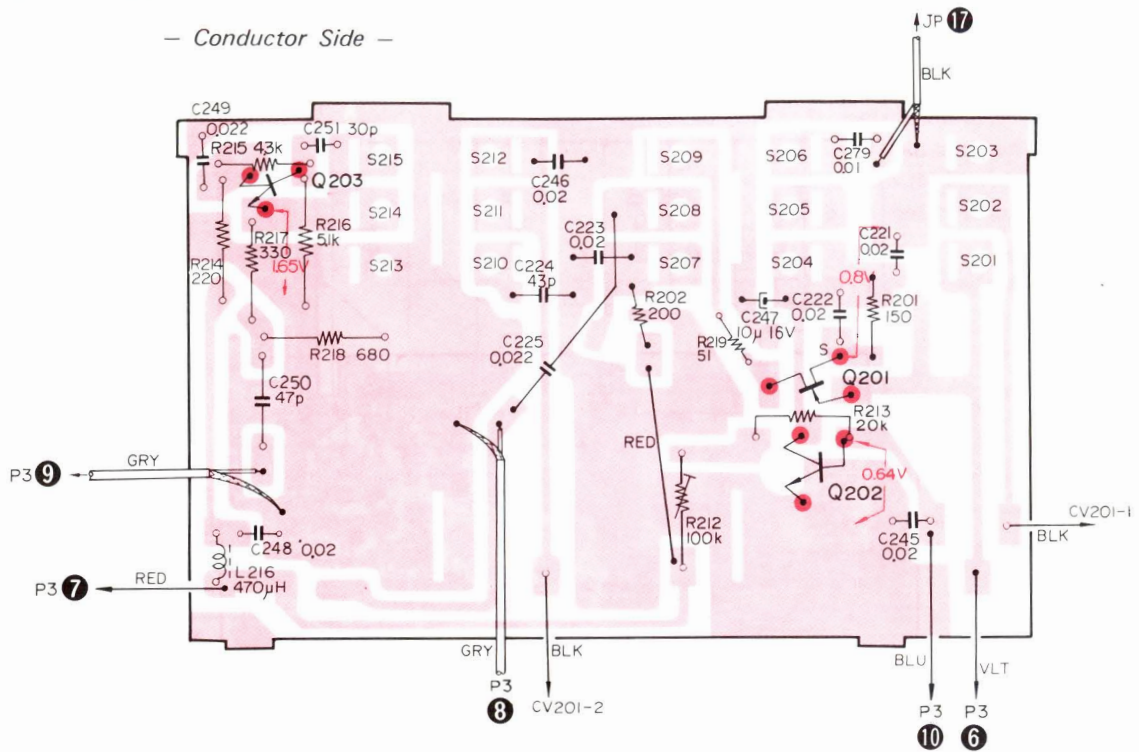

— Component Side —

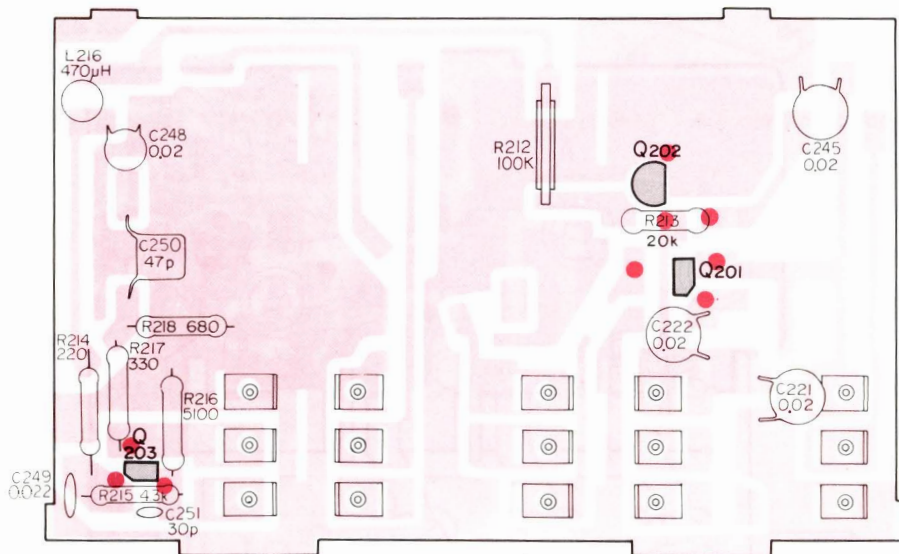
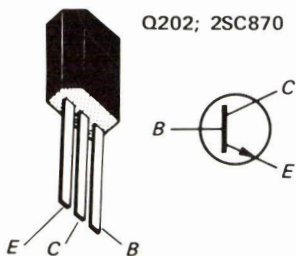
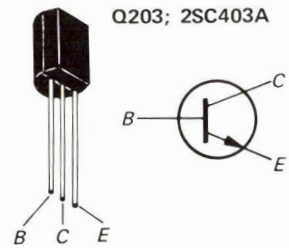
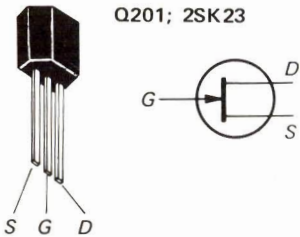

Note:

1. The following parts are mounted on the conductor side: R201, R202, C223, C224, C246, Q201, Q202, and Q203.
2. Printed circuit board; Part No. 1-539-244-11

C201, C203, C205, C207, C211, C213, C215, C217; mounted on the conductor side.

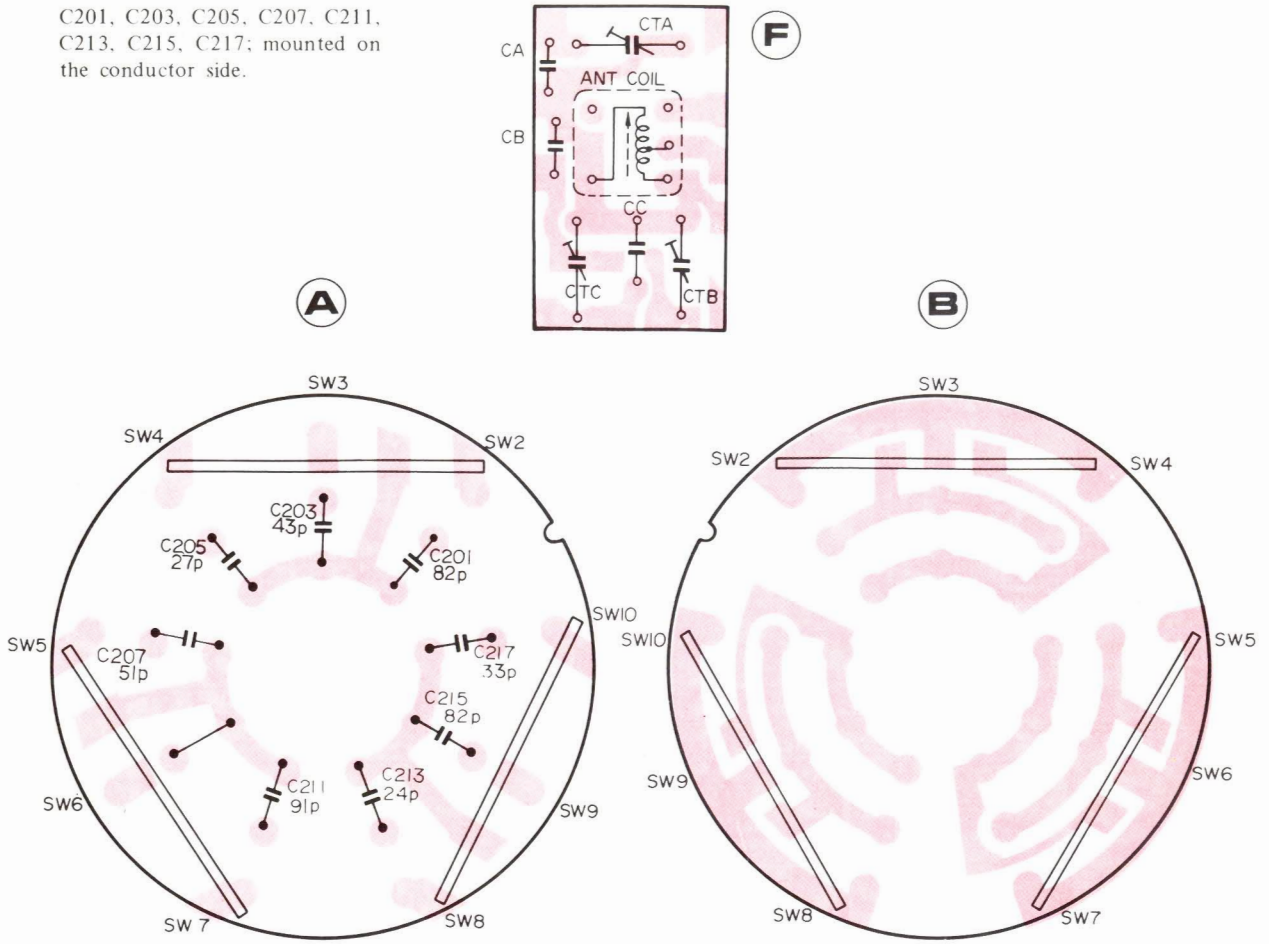

Parts Description on Circuit Board (F)

BAND	ANT COIL	CAPACITOR			TRIMMER CAPACITOR		
		CA	CB	CC	CTA	CTB	CTC
SW2 ~ SW4	L201	C202	C204	C206	CT201	CT202	CT203
		100pF	36pF	8pF			
SW5 ~ SW7	L202	C208	C210	C212	CT204	CT205	CT206
		180pF	39pF	13pF			
SW8 ~ SW10	L203	C214	C216	C218	CT207	CT208	CT209
		16pF	9pF	10pF			

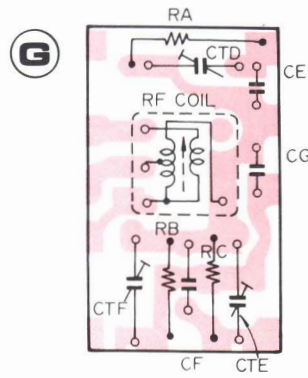

C226, C228, C230, C232, C236, C238, C240, C242; mounted on the conductor side.

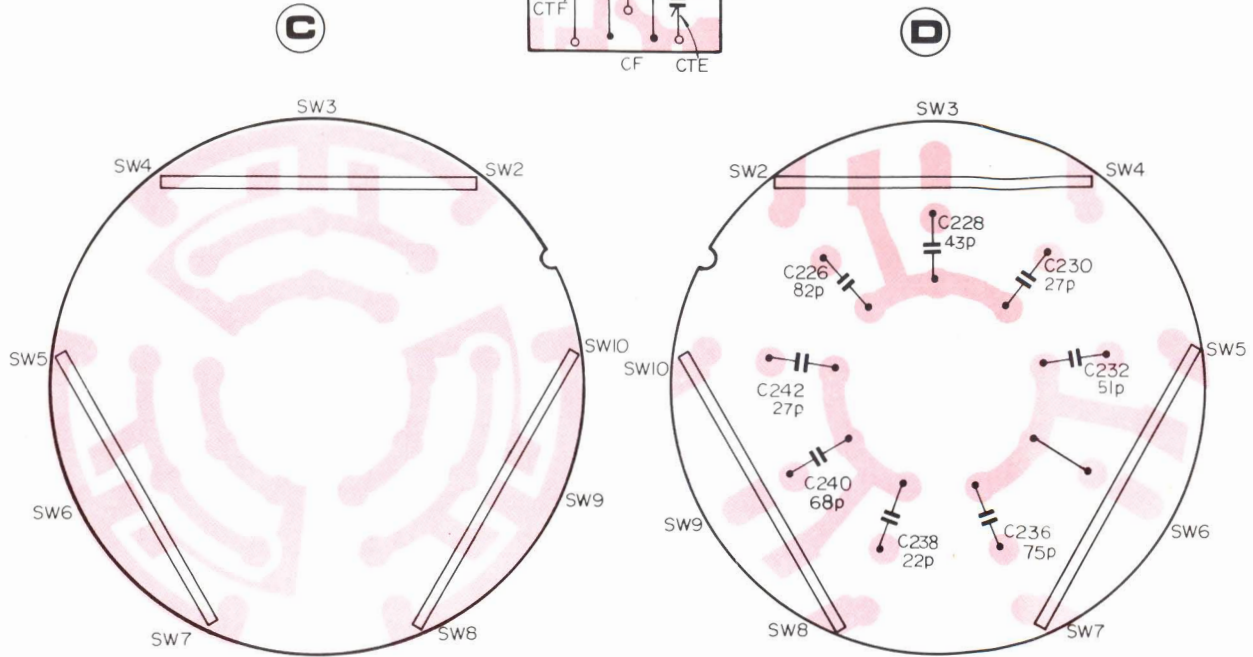

Parts Description on Circuit Board (G)

BAND	RF COIL	CAPACITOR			RESISTOR			TRIMMER CAPACITOR		
		CE	CF	CG	RA	RB	RC	CTD	CTE	CTF
SW2-SW4	L204	C227	C229		R203	R204	R205	CT 210	CT 211	CT 212
		82pF	33pF		3k	2k	1.5k			
SW5-SW7	L205	C233	C235	C237	R206	R207	R208	CT 213	CT 214	CT 215
		150pF	39pF	13pF	4.3k	1.8k	820			
SW8-SW10	L206	C239	C241	C243	R209	R210	R211	CT 216	CT 217	CT 218
		16pF	9pF	10pF	2.7k	2k	1.5k			

RA, RB, RC ; mounted on the conductor side.

C252-C277, L07-L15; mounted on the conductor side.

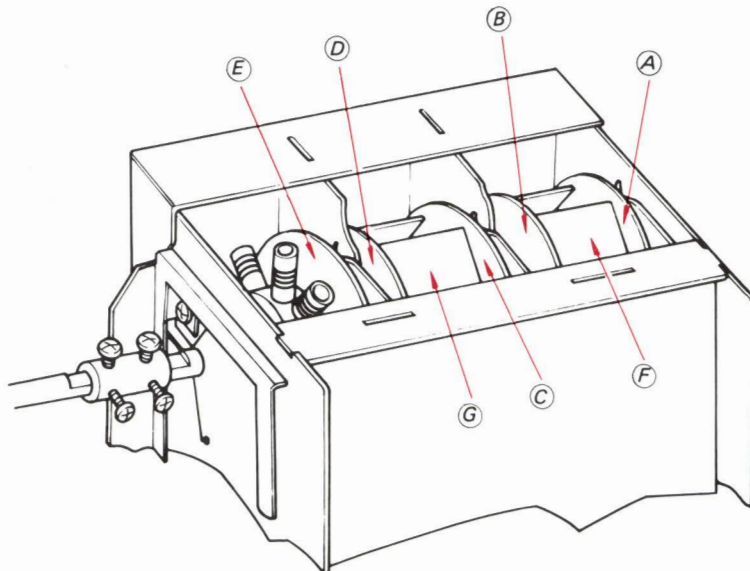
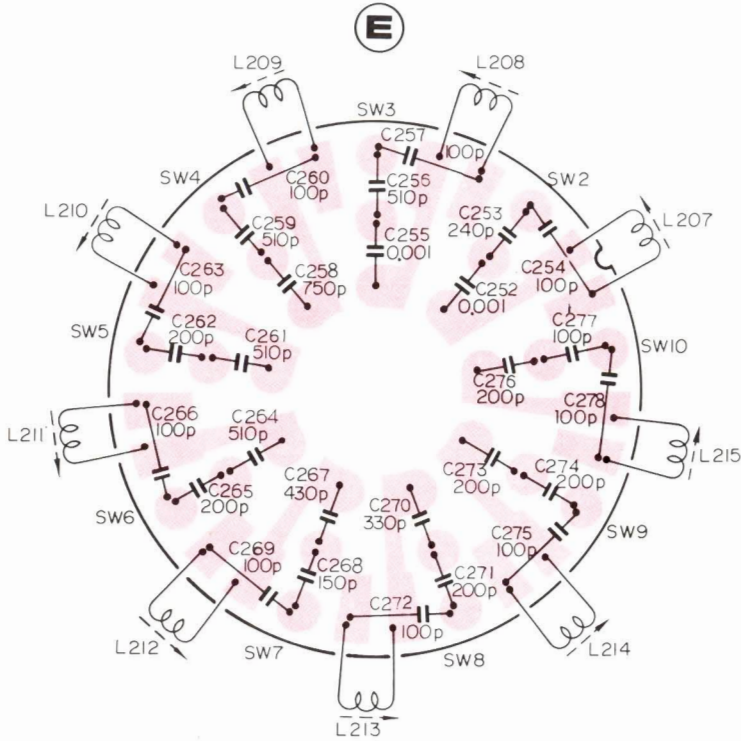

4-3. CP/IF CIRCUIT BOARD (P3)

- Conductor Side -

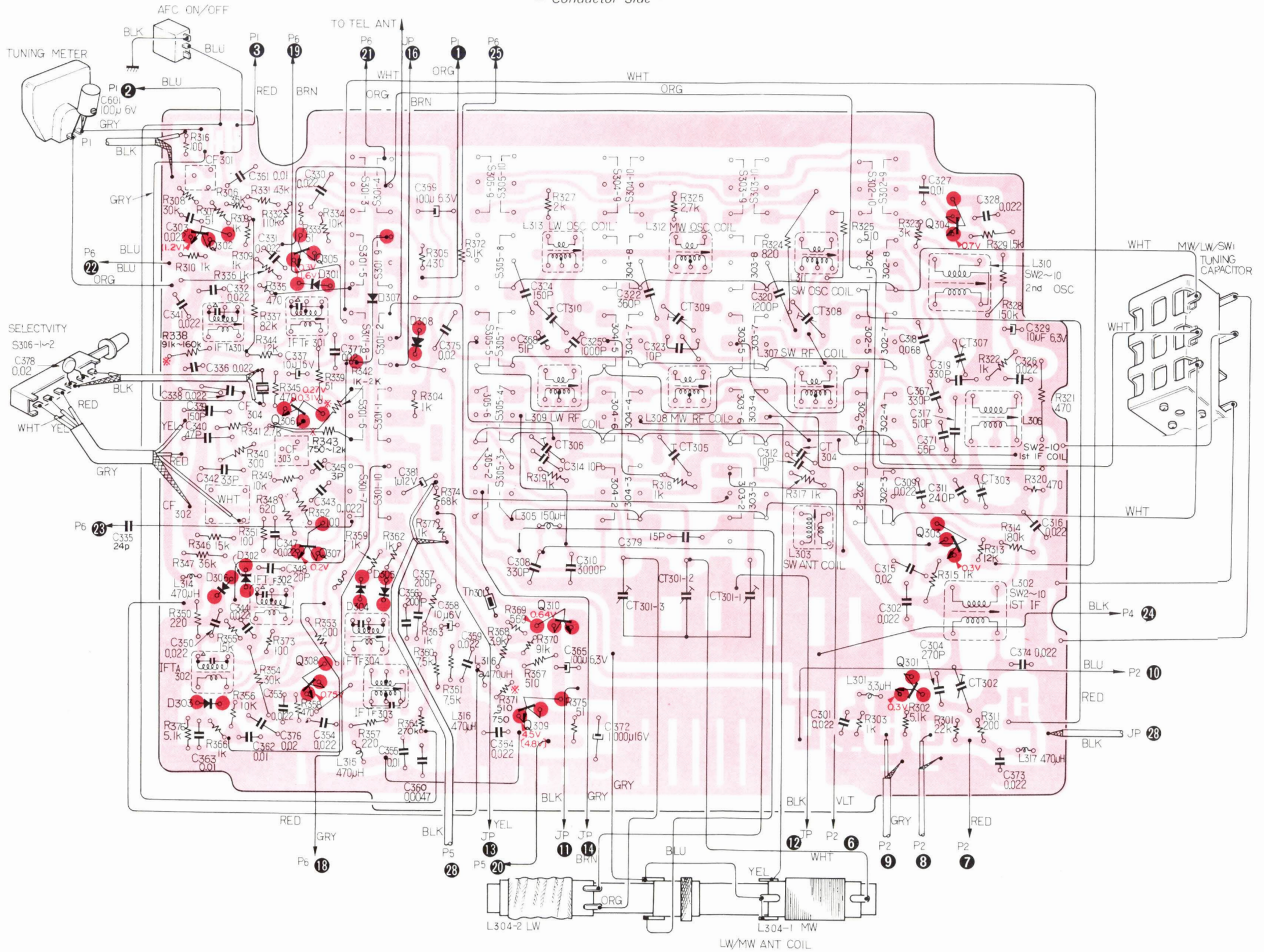

- Component Side -

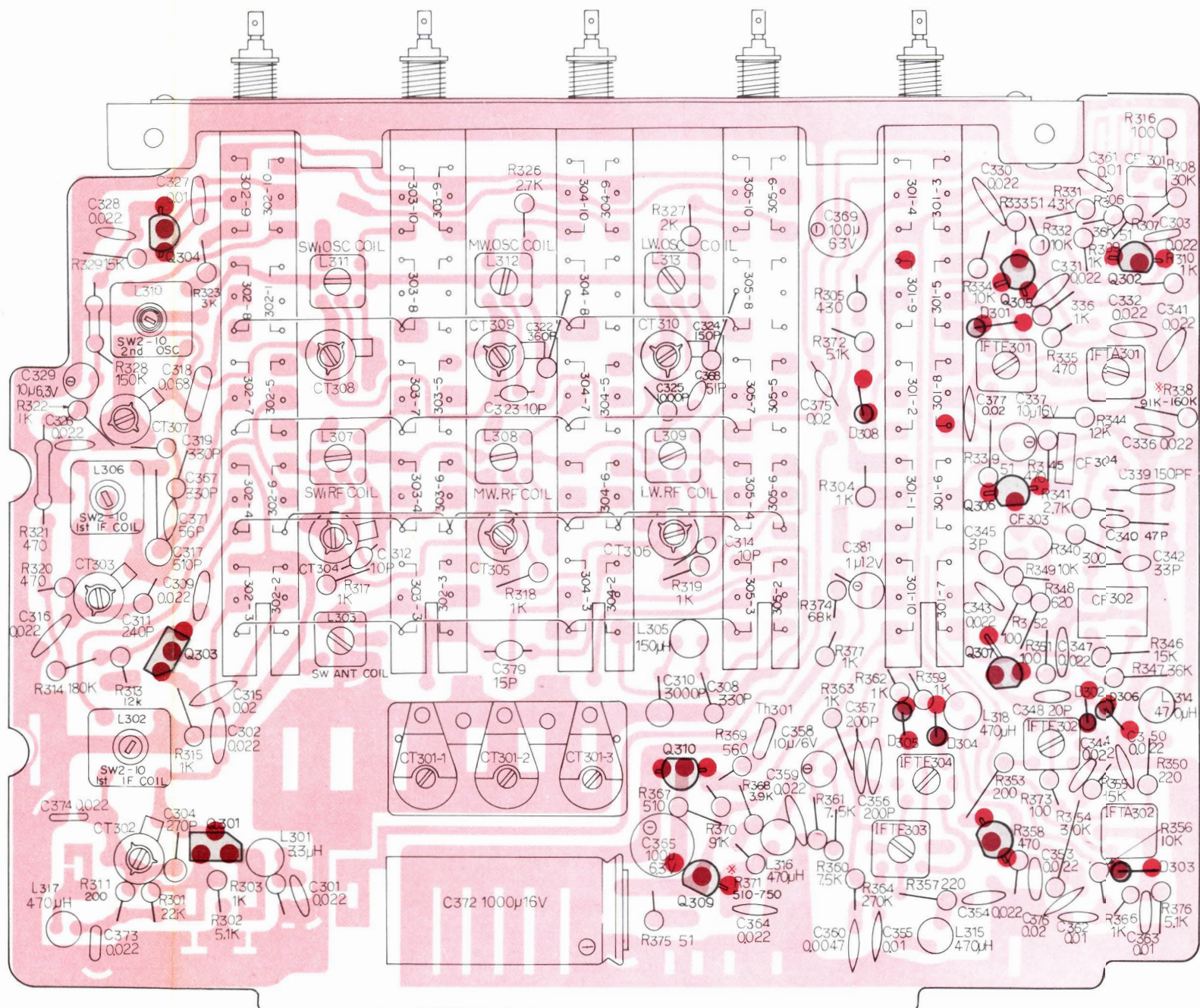

Q301, Q303; 2SC403A

Q302, Q304-Q308; 2SC710
Q309, Q310; 2SC870D301, D302, D304,
D305; 1T262
D303; 1T23
D306; 1T261**Note:**

- The following parts are mounted on the conductor side;
R317, R318, R319, R325, R337, R342, R343, C306,
C319, C345, C347, C361, C369, C371, C376, C377, C379,
L318, D307.
- Printed circuit board; Part No. 1-539-252-12

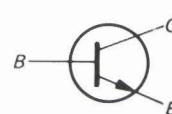
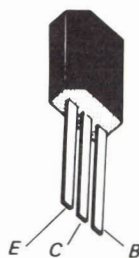

4-4. AF CIRCUIT BOARD (P4)

— Conductor Side —

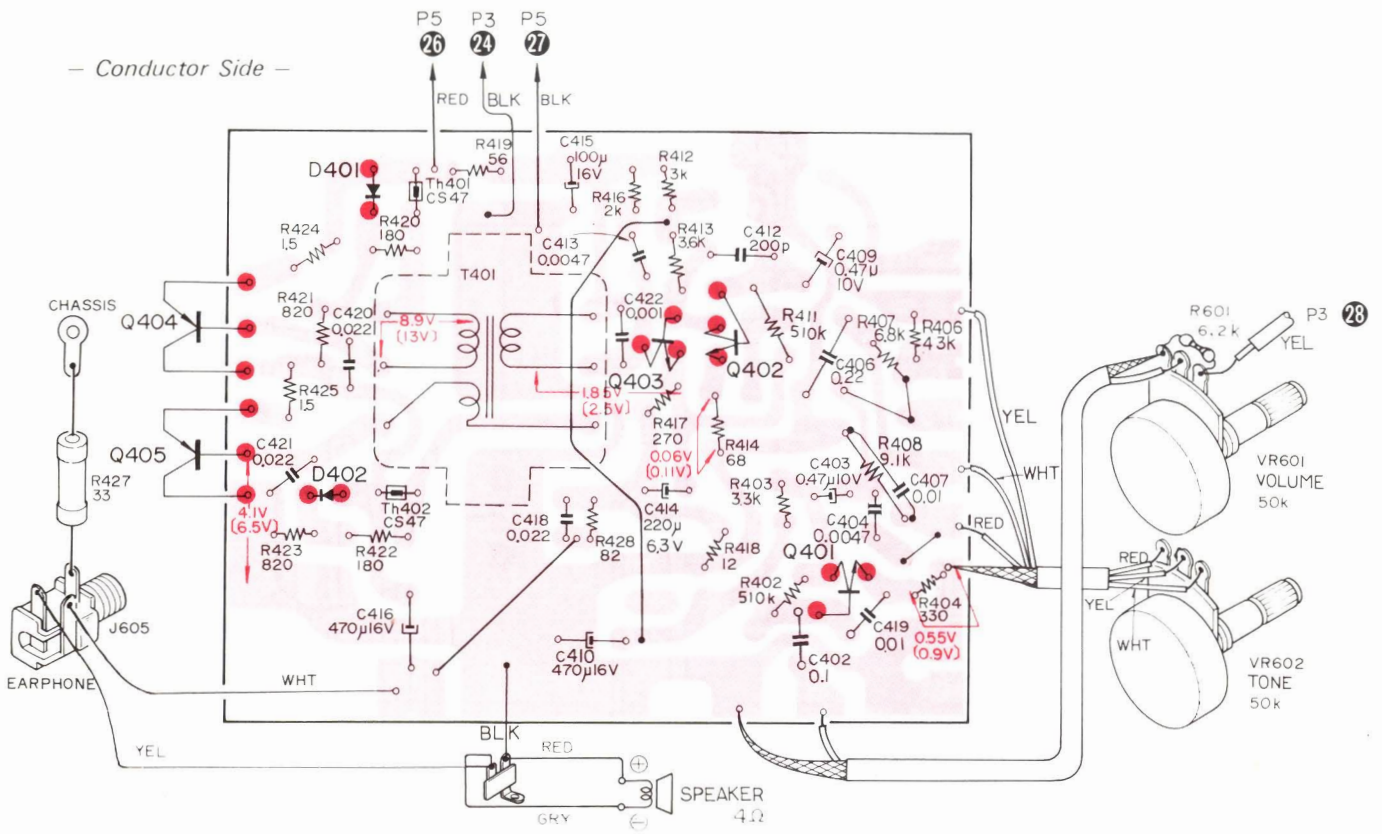

— Component Side —

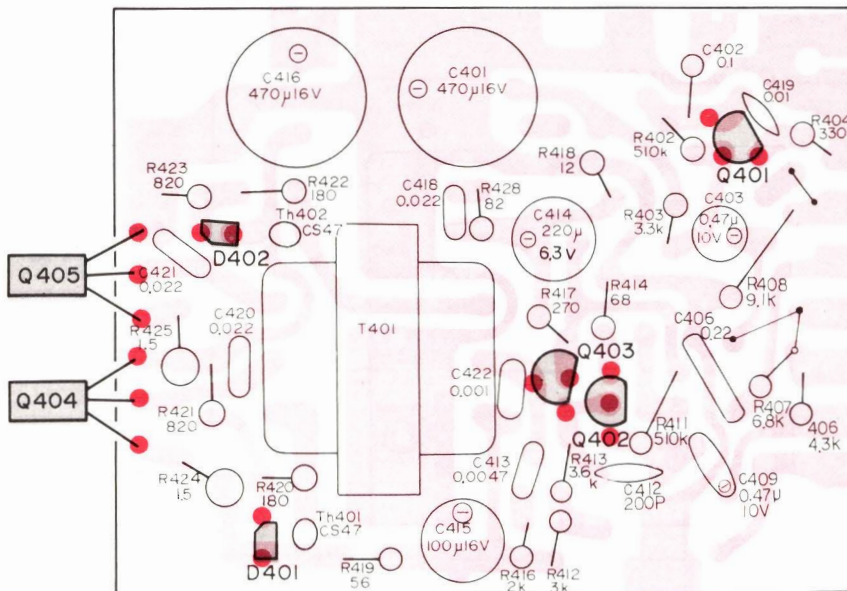

Note:

1. The following parts are mounted on the conductor side; C419, C420, C421, C422.
2. Printed circuit board; Part No. 1-539-253-12

D401, D402; 1T243

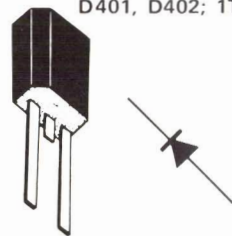

Q401-Q403; 2SC870

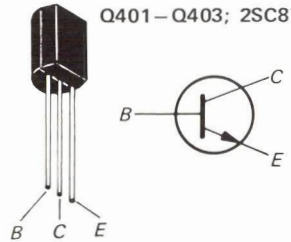

Q404, Q405; 2SB495

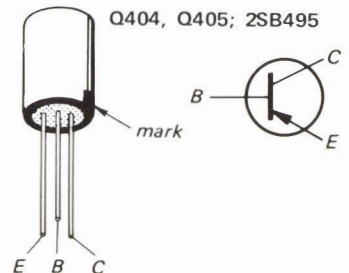

4-5. POWER SUPPLY CIRCUIT BOARD (P5)

— Conductor Side —

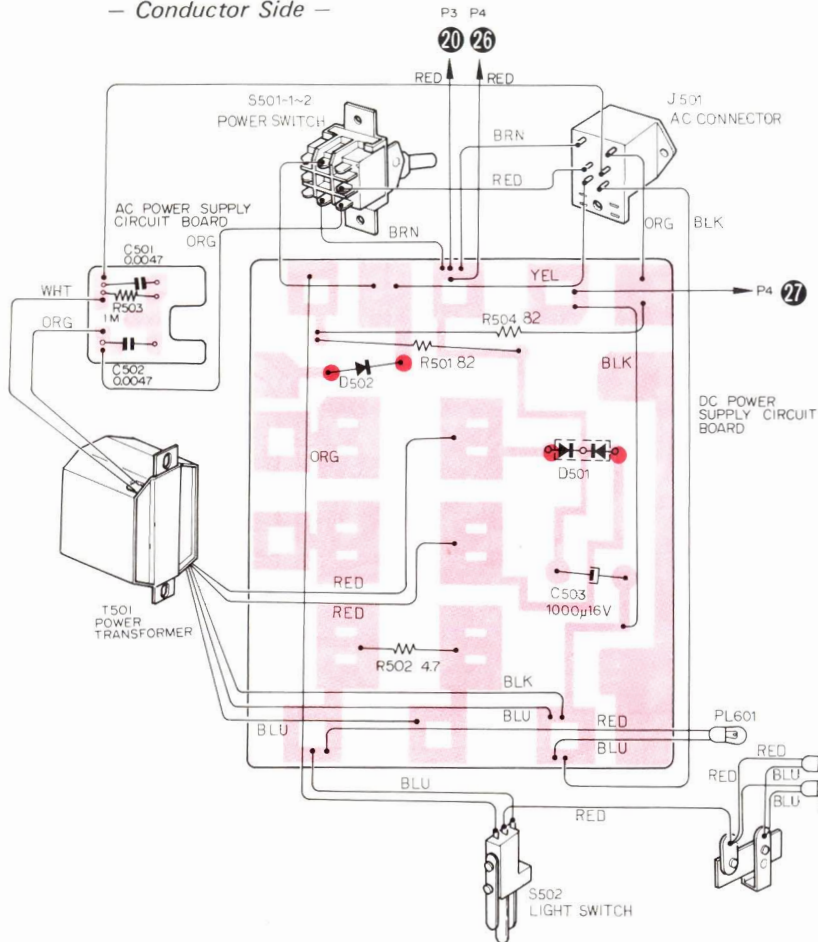

for USA and CANADA model

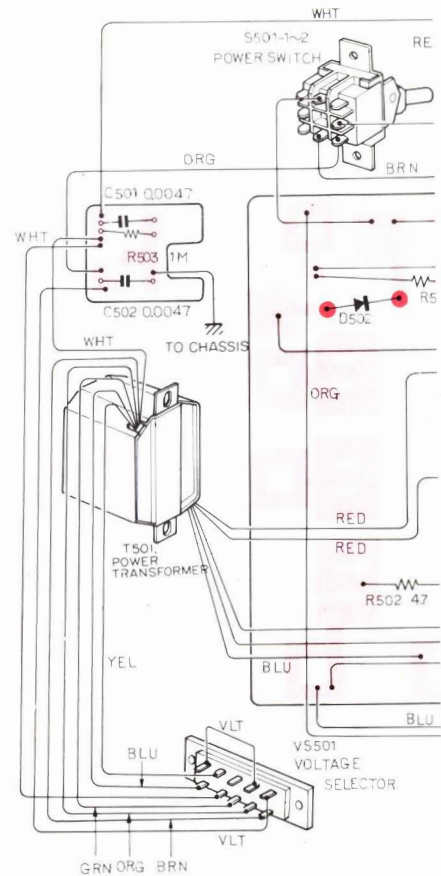

for General Export model

— Component Side —

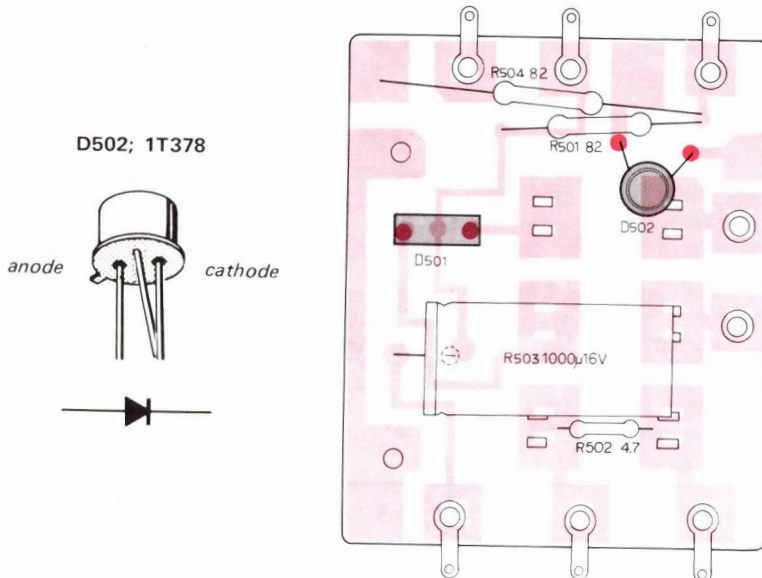

D502; 1T378

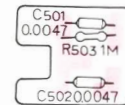
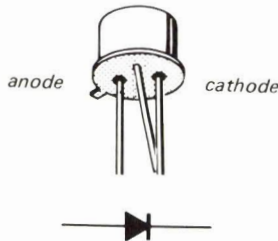

Printed circuit board
Part No. 1-581-103-11

Printed circuit board
Part No. 1-581-104-11

4-6. JACK PANEL (JP)

— Conductor Side —

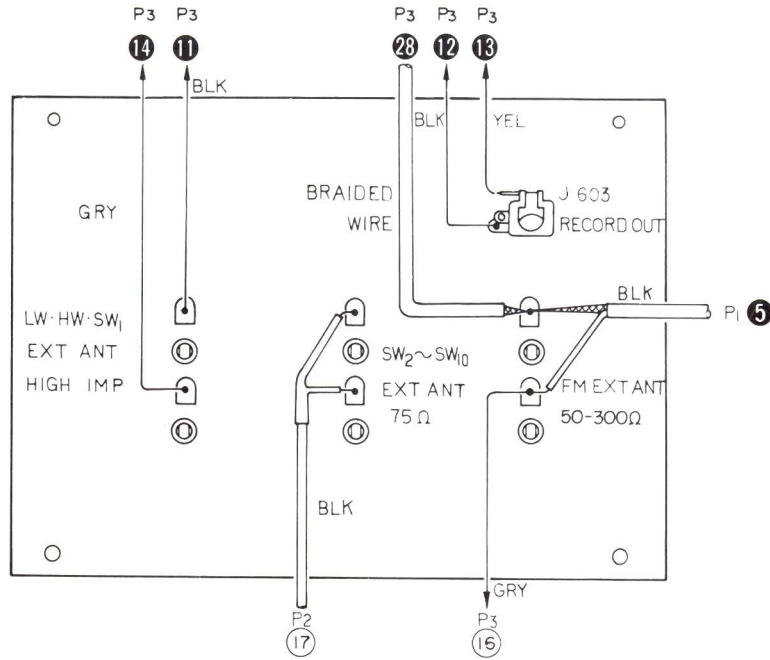

— Component Side —

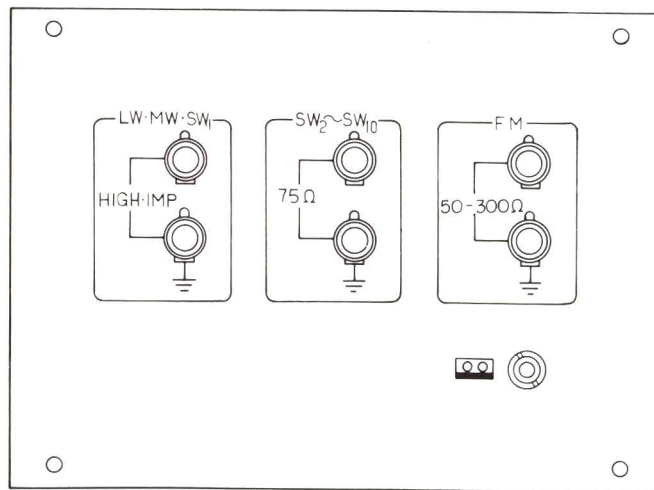

4-7. BFO BLOCK (P6)

— Conductor Side —

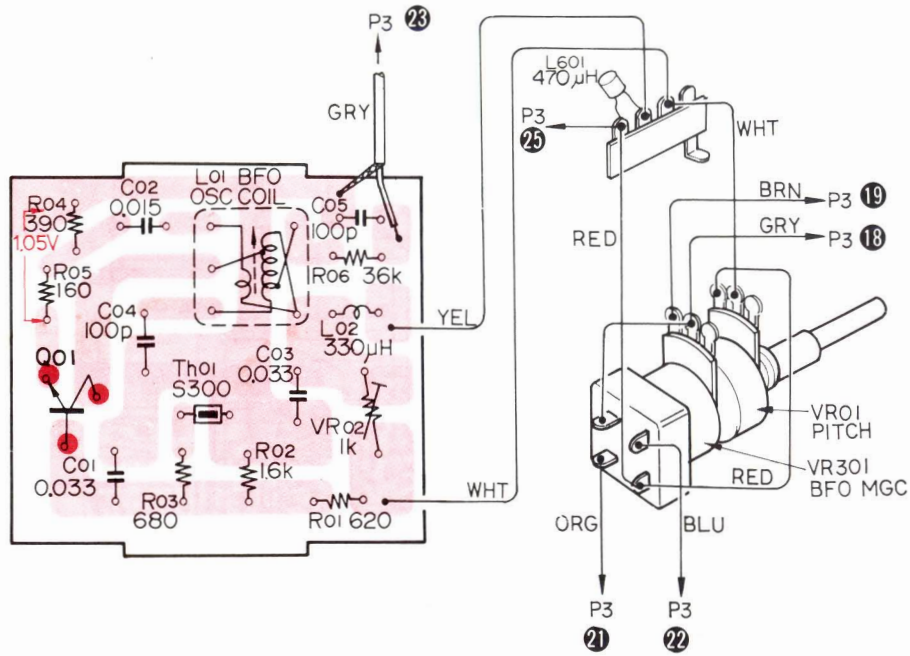

— Component Side —

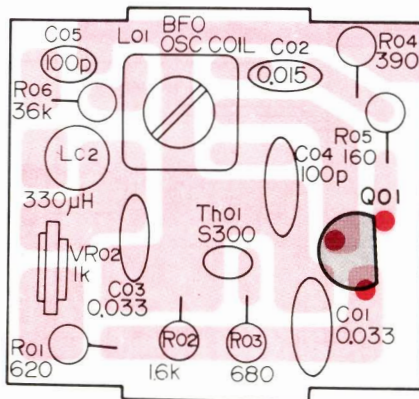

Q01: 2SC710

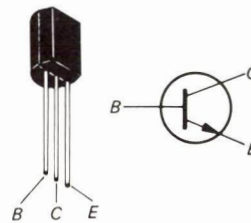

Printed circuit board
Part No. 1-539-629-11

48. WIRING DIAGRAM

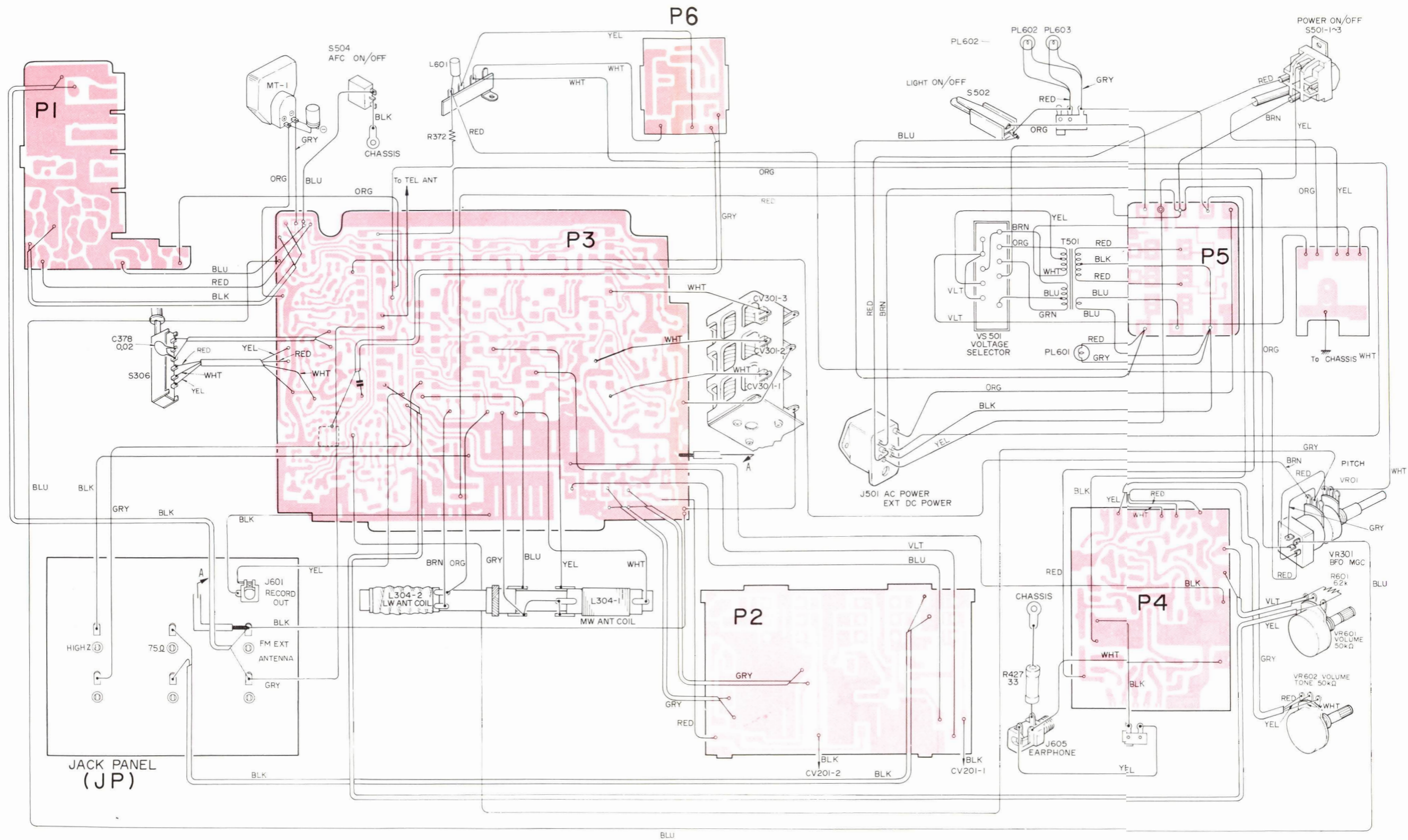

4-9. SCHEMATIC DIAGRAM

Note:

1.  shows grounding to the chassis.
2. All resistors and capacitors are in Ω and μF , unless otherwise indicated.
3. Capacitors marked Δ are built in i-f transformers.
4. The symbol \times indicates a component whose value is selected to yield normal operating condition.
5. Voltage values are measured from point indicated to ground circuit with a dc voltmeter ($20\text{ k}\Omega/\text{V}$) and current values are measured with a dc ammeter. Voltage and current values are taken with no radio signal received.
6. The values shown in () are taken with fm band and in [] with ac power input.
7. Variations may be noted due to normal production tolerances.
8. In USA and Canada model, the voltage selector is omitted.

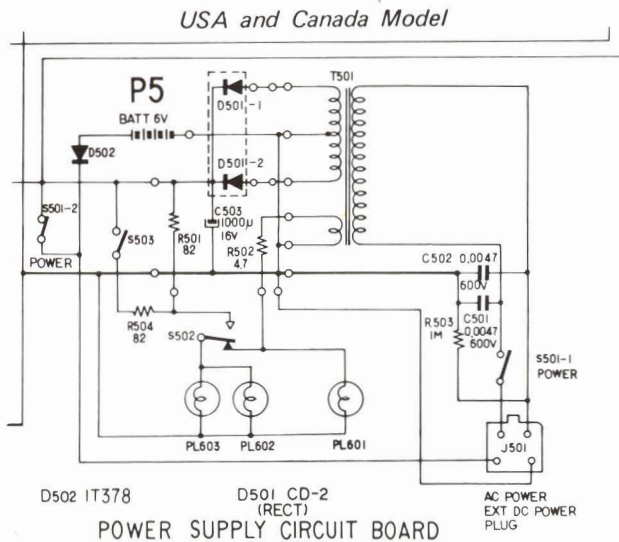

Switch Functions

<u>Ref. No.</u>	<u>Description</u>	<u>Mode</u>
S201-215	Band Selector, SW2-SW10	SW2
S301	Band Selector, FM	OFF
S302	Band Selector, SW2-SW10	OFF
S303	Band Selector, SW1	OFF
S304	Band Selector, MW	ON
S305	Band Selector, LW	OFF
S306	SELECTIVITY BROAD-SHARP	BROAD
S501	Power ON-OFF	ON
S502	Pilot Lamp	ON
S503	EXT DC Power	OFF
S504	AFC ON-OFF	ON

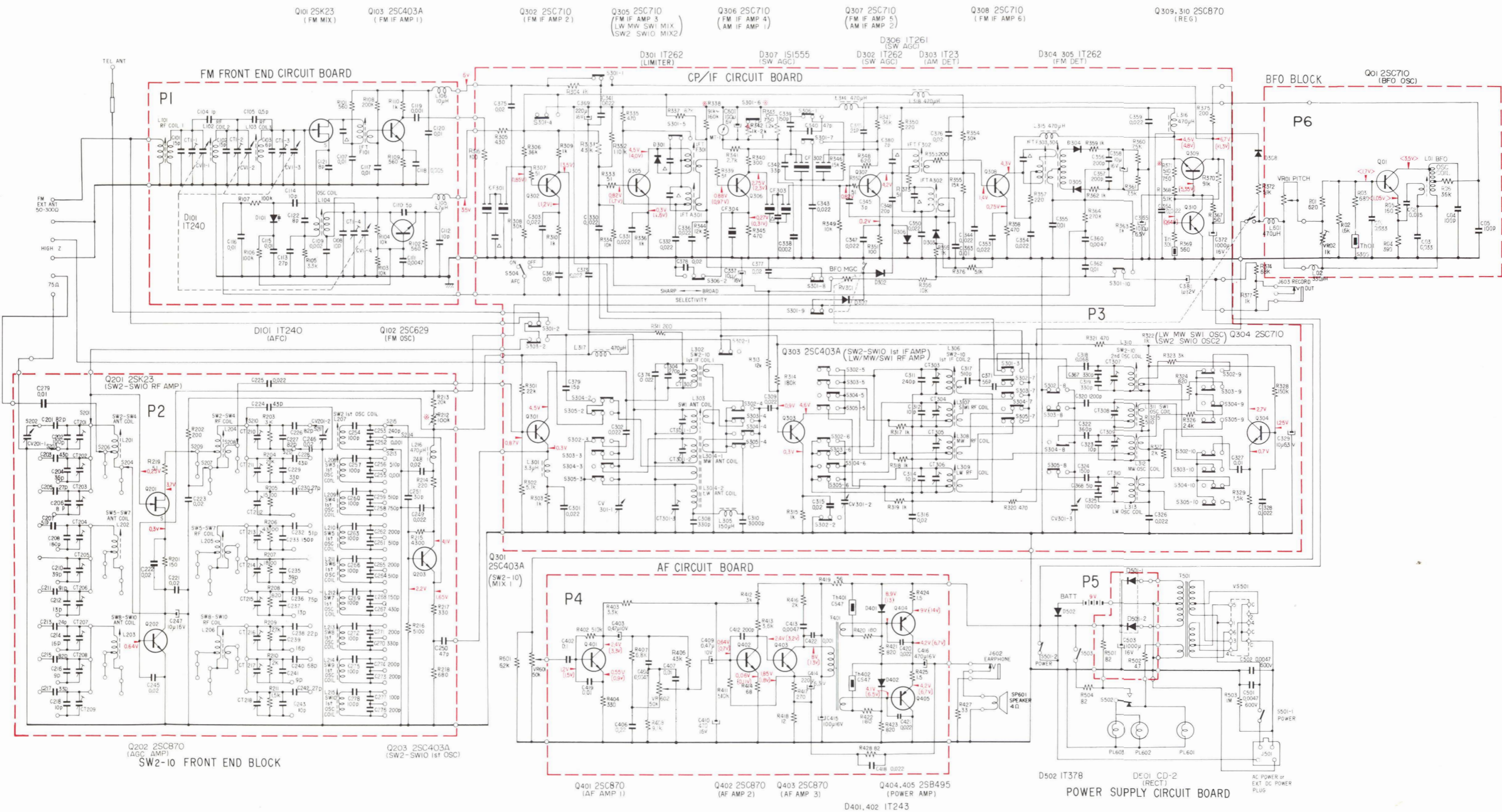

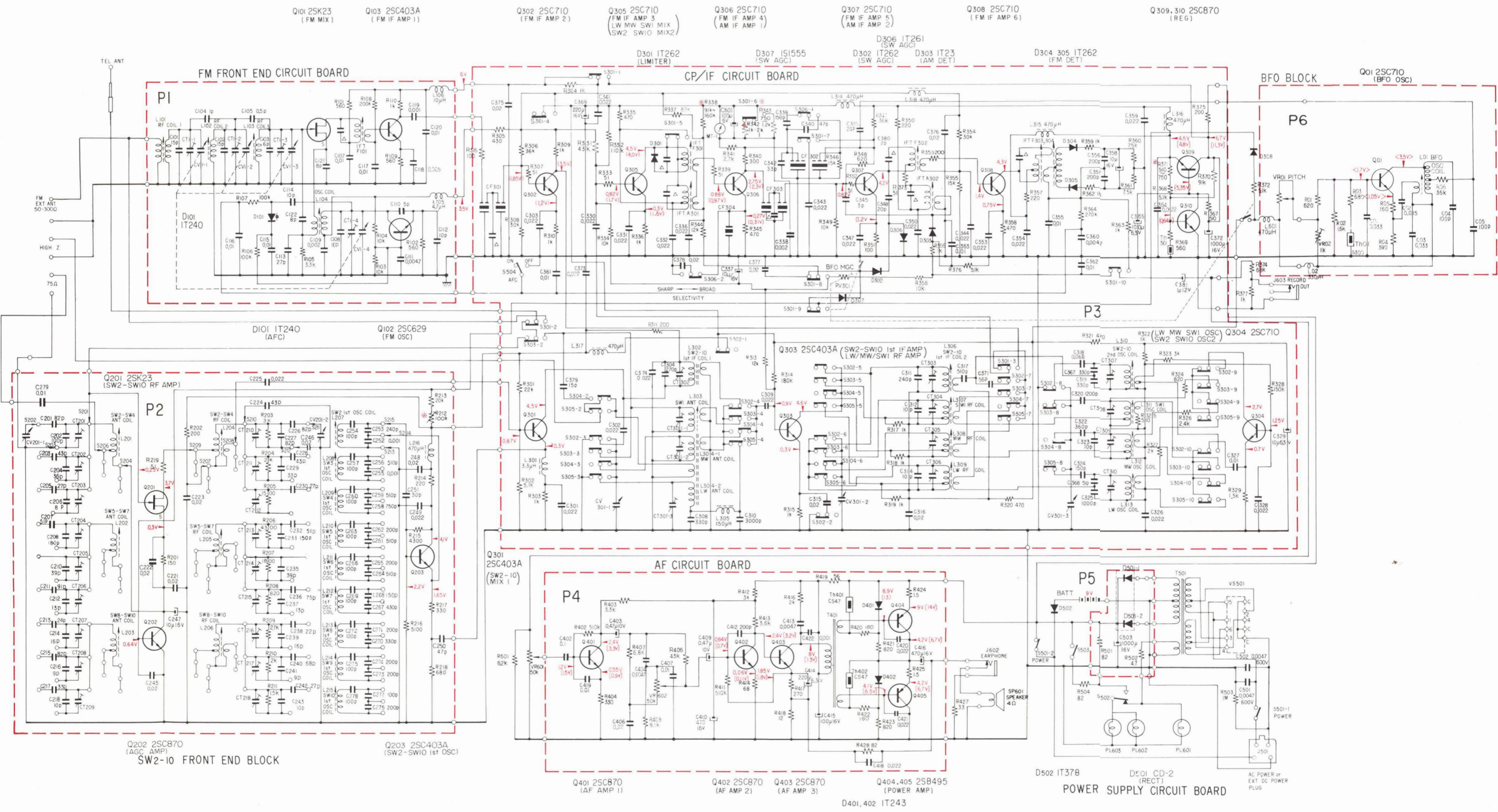

SECTION 5 PACKING AND EXPLODED VIEW

5-1. PACKING

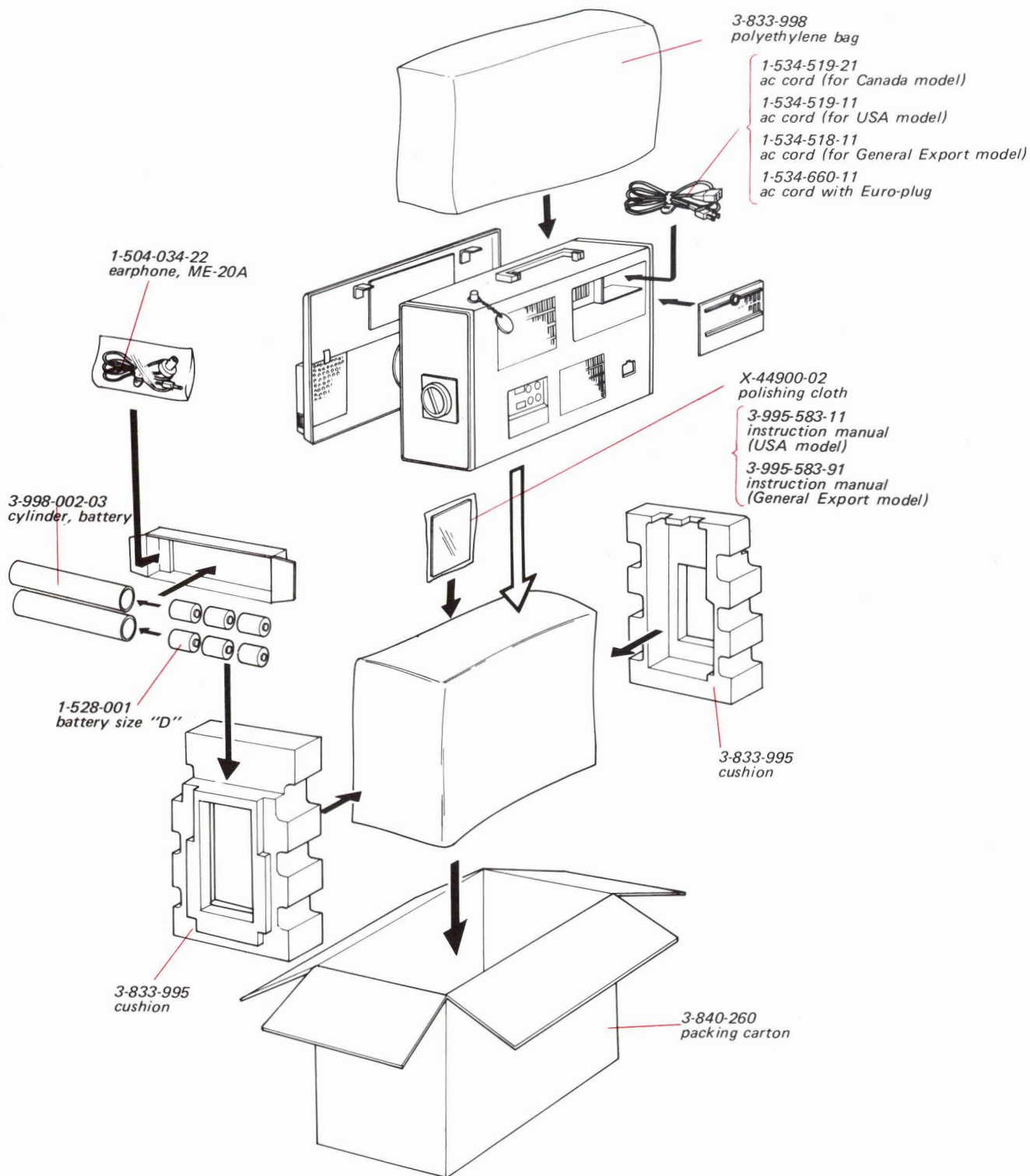

5-2. EXPLODED VIEW (1)

Note:

The parts marked * are included in cabinet ass'y, X-38402-02
 The parts marked ★ are included in front cover ass'y, X-38402-85-1
 The parts marked ⊙ are included in battery lid ass'y, X-38402-83-1
 The parts marked ▲ are included in rear cover ass'y, X-38402-87-1

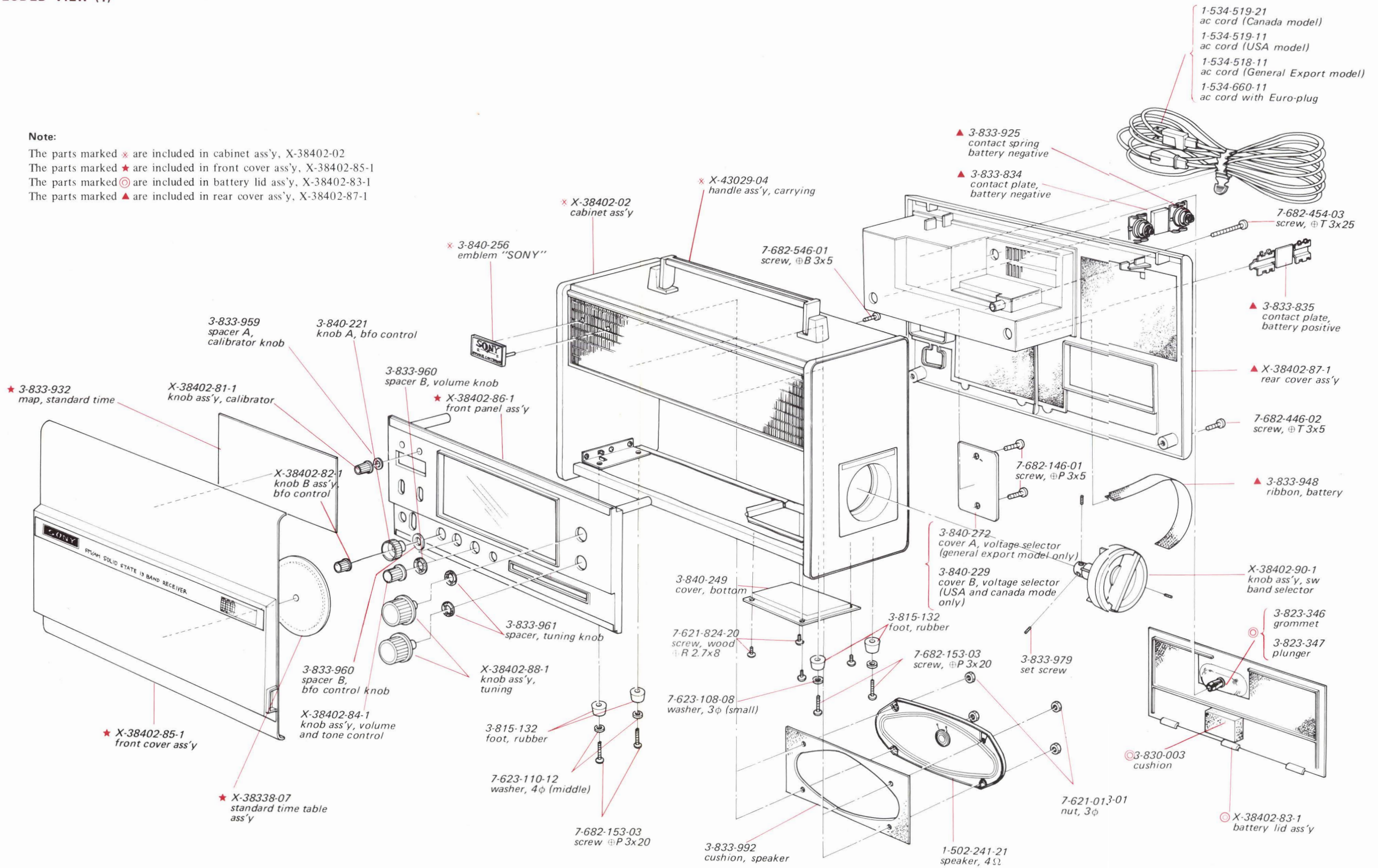

EXPLODED VIEW (2)

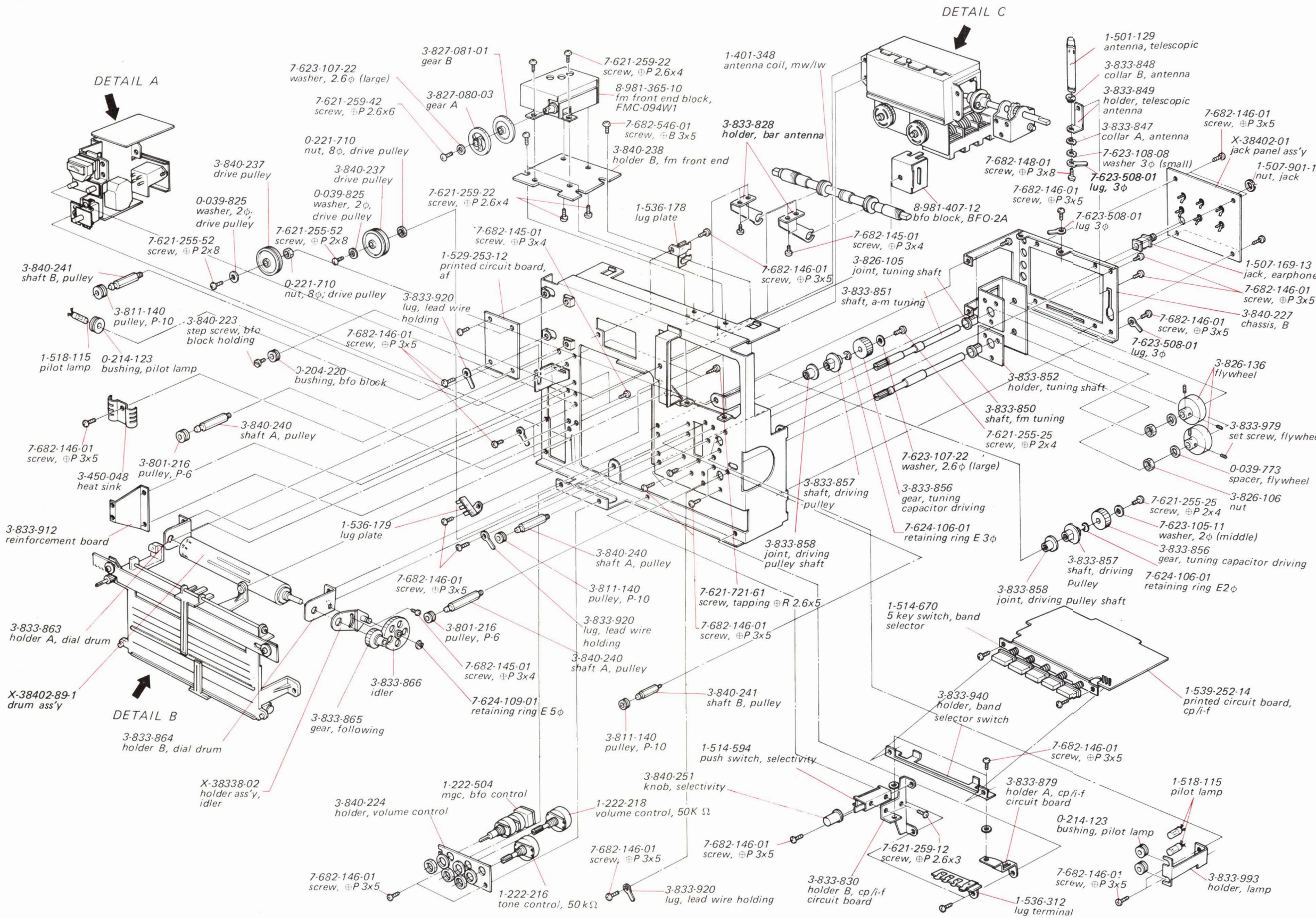

EXPLODED VIEW (3)

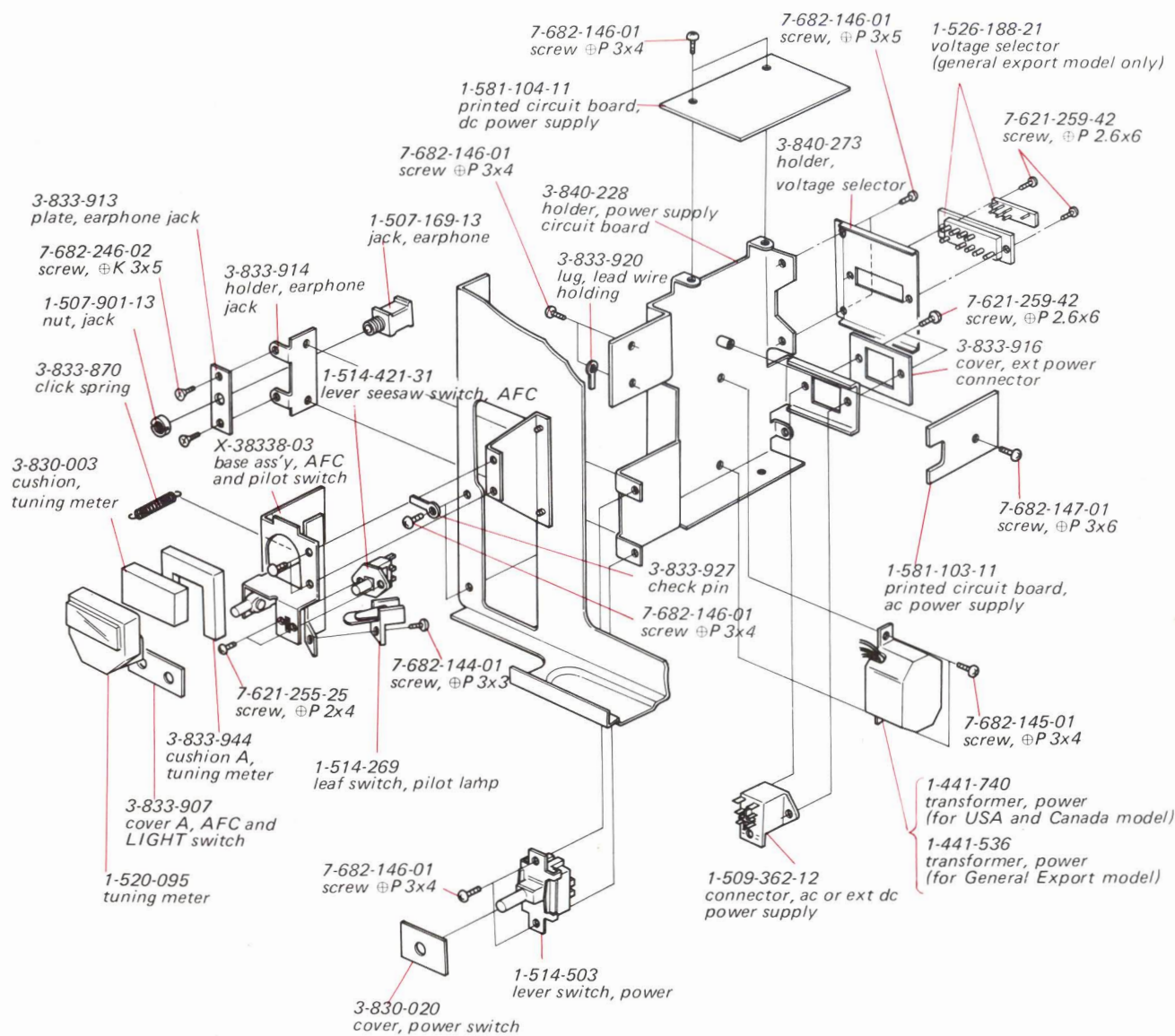

DETAIL "A"

EXPLODED VIEW (4)

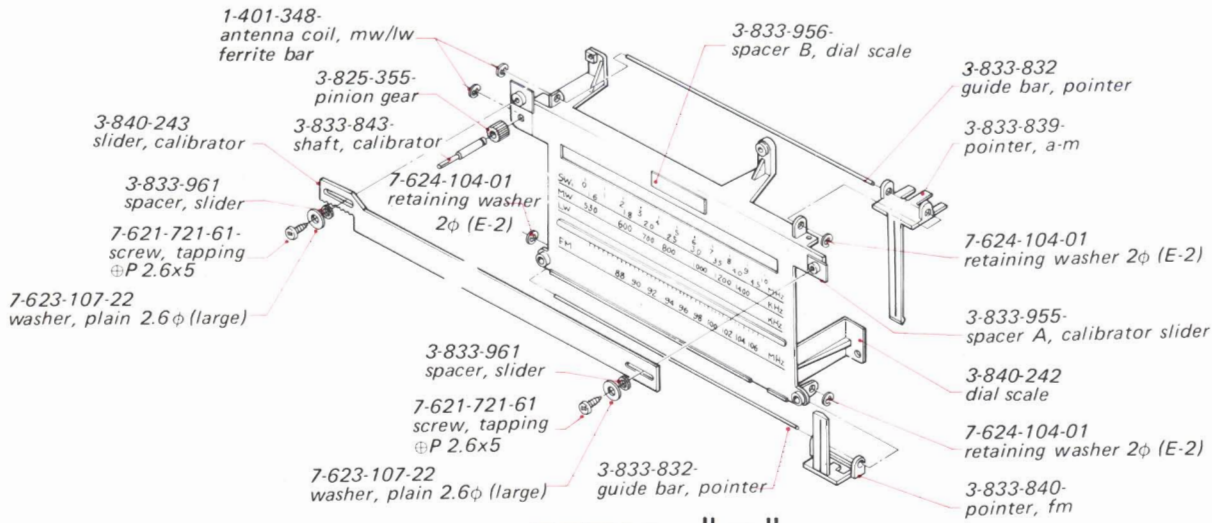

DETAIL "B"

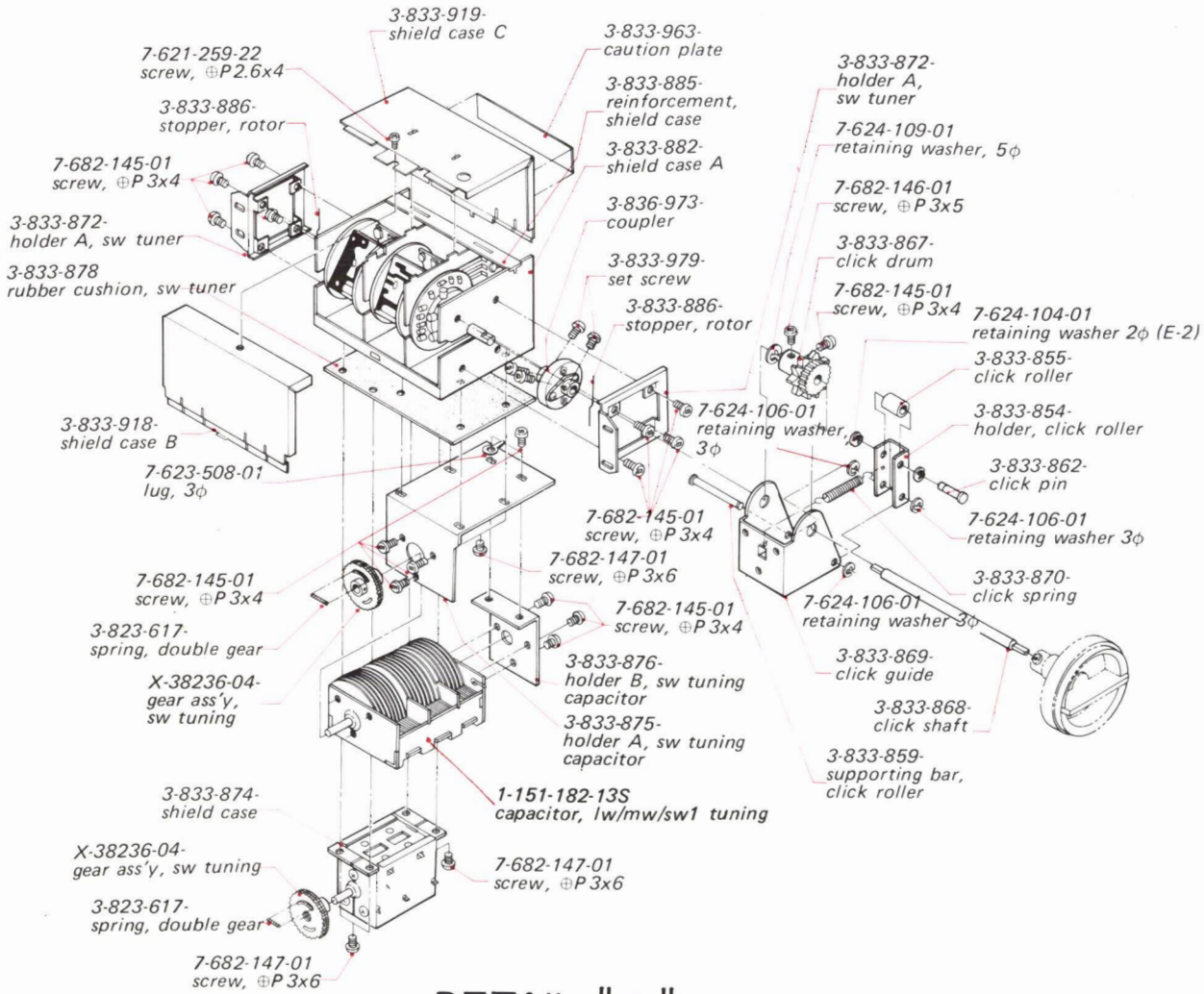

DETAIL "C"

SECTION 6 ELECTRICAL PARTS LIST

<u>Ref. No.</u>	<u>Part No.</u>	<u>Description</u>	<u>Ref. No.</u>	<u>Part No.</u>	<u>Description</u>
SEMICONDUCTORS					
Q101		transistor (FET) 2SK23	L207	1-405-419	1st osc coil, SW2
Q102		transistor 2SC629	L208	1-405-420	1st osc coil, SW3
Q103		transistor 2SC403A	L209	1-405-421	1st osc coil, SW4
Q201		transistor (FET) 2SK23	L210	1-405-422	1st osc coil, SW5
Q202		transistor 2SC870	L211	1-405-423	1st osc coil, SW6
Q203		transistor 2SC403A	L212	1-405-424	1st osc coil, SW7
Q301		transistor 2SC403A	L213	1-405-425	1st osc coil, SW8
Q302		transistor 2SC710	L214	1-405-426	1st osc coil, SW9
Q303		transistor 2SC403A	L215	1-405-427	1st osc coil, SW10
Q304		transistor 2SC710	L216	1-407-177	470 μ H, micro inductor
Q305		transistor 2SC710	L301	1-407-184	3.3 μ H, micro inductor
Q306		transistor 2SC710	L302	1-425-442	1st i-f coil, SW2-SW10
Q307		transistor 2SC710	L303	1-401-408	antenna coil, SW1
Q308		transistor 2SC710	L304	1-401-348	antenna coil, MW/LW
Q309		transistor 2SC870	L305	1-407-171	15 μ H, micro inductor
Q310		transistor 2SC870	L306	1-425-442	1st i-f coil, SW2-SW10
Q401		transistor 2SC870	L307	1-425-577	rf coil, SW1
Q402		transistor 2SC870	L308	1-425-578	rf coil, MW
Q403		transistor 2SC870	L309	1-425-582	rf coil, LW
Q404		transistor 2SB495	L310	1-425-576	2nd osc coil, SW2-SW10
Q405		transistor 2SB495	L311	1-405-408	osc coil, SW1
Q01		transistor 2SC710	L312	1-405-409	osc coil, MW
D101		diode 1T240	L313	1-405-410	osc coil, LW
D301		diode 1T262	L314	1-407-177	470 μ H, micro inductor
D302		diode 1T262	L315	1-407-177	470 μ H, micro inductor
D303		diode 1T23	L316	1-407-177	470 μ H, micro inductor
D304		diode 1T262	L317	1-407-177	470 μ H, micro inductor
D305		diode 1T262	L318	1-407-177	470 μ H, micro inductor
D306		diode 1T261	L01	1-405-450	osc coil, bfo
D307		diode 1S1555	L02	1-407-175	330 μ H, micro inductor
D308		diode 1S1555	IFTF101	1-403-294	transformer, fm i-f
D401		diode 1T243	IFTF301	1-403-244-15	transformer, fm i-f
D402		diode 1T243	IFTF302	1-403-244-15	transformer, fm i-f
D501		diode CD-2	IFTF303	1-403-272-15	transformer, fm discriminator
D502		diode 1T378	IFTF304	1-403-288-11	transformer, fm discriminator
Th401	8-691-002-11	thermistor CS-47	IFTA301	1-403-026-21	transformer, a-m i-f
Th402	8-691-002-11	thermistor CS-47	IFTA302	1-403-137-11	transformer, a-m i-f
Th01	8-690-005-00	thermistor S-300	CF301	1-527-501-15	ceramic filter, fm 10.76 MHz
COILS AND TRANSFORMERS					
L101	1-425-526	rf coil 1, fm	CF302	1-403-161-13	ceramic filter, a-m
L102	1-425-525	rf coil 2, fm	CF303	1-527-501-15	ceramic filter, fm 10.76 MHz
L103	1-425-525	rf coil 3, fm	CF304	1-403-154-11	ceramic filter, a-m
L104	1-405-386	osc coil, fm	T401	1-423-140	transformer, driver
L105	1-407-186	4.7 μ H, micro inductor	T501	1-441-740	transformer, power (for USA and Canada Model)
L106	1-407-190	10 μ H, micro inductor		1-441-536	transformer, power (for General Export Model)
L201	1-401-405	antenna coil, SW2-SW4	CAPACITORS		
L202	1-401-406	antenna coil, SW5-SW7	C101	1-101-861	15pF ceramic
L203	1-401-407	antenna coil, SW8-SW10	C102	1-101-861	15pF ceramic
L204	1-425-579	rf coil, SW2-SW4	C103	1-101-956	6pF ceramic
L205	1-425-580	rf coil, SW5-SW7	C104	1-101-937	1pF ceramic
L206	1-425-581	rf coil, SW8-SW10			

<u>Ref. No.</u>	<u>Part No.</u>	<u>Description</u>		<u>Ref. No.</u>	<u>Part No.</u>	<u>Description</u>	
C105	1-101-936	0.5pF	ceramic	C236	1-107-082	75pF	silvered mica
C106		- discarded -		C237	1-107-064	13pF	silvered mica
C107	1-101-864	0.01 μ F	ceramic	C238	1-107-069	22pF	silvered mica
C108	1-102-508	10pF	ceramic	C239	1-107-066	16pF	silvered mica
C109	1-102-089	0.0022 μ F	ceramic	C240	1-107-081	68pF	silvered mica
C110	1-102-864	5pF	ceramic	C241	1-107-106	9pF	silvered mica
C111	1-102-090	0.0047 μ F	ceramic	C242	1-107-071	27pF	silvered mica
C112	1-102-508	10pF	ceramic	C243		- discarded -	
C113	1-101-869	27pF	ceramic	C244		- discarded -	
C114	1-101-976	10pF	ceramic	C245	1-101-924	0.02 μ F	ceramic
C115	1-101-072	0.01 μ F	ceramic	C246	1-101-924	0.02 μ F	ceramic
C116	1-101-072	0.01 μ F	ceramic	C247	1-121-398	10 μ F 16V	electrolytic
C117	1-101-072	0.01 μ F	ceramic	C248	1-101-924	0.02 μ F	ceramic
C118	1-105-829-12	0.005 μ F	mylar	C249	1-105-837-12	0.022 μ F	mylar
C119	1-101-918	0.001 μ F	ceramic	C250	1-107-077	47pF	silvered mica
C120	1-101-072	0.01 μ F	ceramic	C251	1-107-072	30pF	silvered mica
C121	1-101-958	8pF	ceramic	C252	1-105-661-12	0.001 μ F	mylar
C122	1-101-958	8pF	ceramic	C253	1-103-610	240pF	styrol
C201	1-107-083	82pF	silvered mica	C254	1-102-734	100pF	ceramic
C202	1-107-085	100pF	silvered mica	C255	1-105-661-12	0.001 μ F	mylar
C203	1-107-076	43pF	silvered mica	C256	1-103-618	510pF	styrol
C204	1-107-074	36pF	silvered mica	C257	1-102-702	100pF	ceramic
C205	1-107-071	27pF	silvered mica	C258	1-103-622	750pF	styrol
C206	1-107-105	8pF	silvered mica	C259	1-103-618	510pF	styrol
C207	1-107-078	51pF	silvered mica	C260	1-102-702	100pF	ceramic
C208	1-107-091	180pF	silvered mica	C261	1-103-618	510pF	styrol
C209		- discarded -		C262	1-103-608	200pF	styrol
C210	1-107-075	39pF	silvered mica	C263	1-102-702	100pF	ceramic
C211	1-107-084	91pF	silvered mica	C264	1-103-618	510pF	styrol
C212	1-107-064	13pF	silvered mica	C265	1-103-608	200pF	styrol
C213	1-107-070	24pF	silvered mica	C266	1-102-702	100pF	ceramic
C214	1-107-066	16pF	silvered mica	C267	1-103-616	430pF	styrol
C215	1-107-083	82pF	silvered mica	C268	1-103-605	150pF	styrol
C216	1-107-106	9pF	silvered mica	C269	1-102-734	100pF	ceramic
C217	1-107-073	33pF	silvered mica	C270	1-103-613	330pF	styrol
C218	1-107-061	10pF	silvered mica	C271	1-103-608	200pF	styrol
C219		- discarded -		C272	1-102-702	100pF	ceramic
C220		- discarded -		C273	1-103-608	200pF	styrol
C221	1-101-924	0.02 μ F	ceramic	C274	1-103-608	200pF	styrol
C222	1-101-924	0.02 μ F	ceramic	C275	1-102-734	100pF	ceramic
C223	1-101-924	0.02 μ F	ceramic	C276	1-103-608	200pF	styrol
C224	1-107-076	43pF	silvered mica	C277	1-103-601	100pF	styrol
C225	1-105-837-12	0.022 μ F	mylar	C278	1-102-734	100pF	ceramic
C226	1-107-083	82pF	silvered mica	C279	1-101-923	0.01 μ F	ceramic
C227	1-107-083	82pF	silvered mica	C301	1-105-677-12	0.022 μ F	mylar
C228	1-107-076	43pF	silvered mica	C302	1-105-677-12	0.022 μ F	mylar
C229	1-107-073	33pF	silvered mica	C303	1-105-677-12	0.022 μ F	mylar
C230	1-107-071	27pF	silvered mica	C304	1-103-611	270pF	styrol
C231		- discarded -		C305		- discarded -	
C232	1-107-078	51pF	silvered mica	C306		- discarded -	
C233	1-107-089	150pF	silvered mica	C307		- discarded -	
C234		- discarded -		C308	1-103-613	330pF	styrol
C235	1-107-075	39pF	silvered mica	C309	1-105-677-12	0.022 μ F	mylar

<i>Ref. No.</i>	<i>Part No.</i>	<i>Description</i>		<i>Ref. No.</i>	<i>Part No.</i>	<i>Description</i>	
C310	1-103-636	3,000pF	styrol	C363	1-105-673-12	0.01 μ F	mylar
C311	1-103-610	240pF	styrol	C364	1-105-677-12	0.022 μ F	mylar
C312	1-101-959	10pF	ceramic	C365	1-121-413	100 μ F 6.3V	electrolytic
C313		- discarded -		C366		- discarded -	
C314	1-101-959	10pF	ceramic	C367	1-103-613	330pF	styrol
C315	1-101-924	0.02 μ F	ceramic	C368	1-101-882	51pF	ceramic
C316	1-105-677-12	0.022 μ F	mylar	C369	1-121-413	100 μ F 6.3V	electrolytic
C317	1-103-618	510pF	styrol	C370		- discarded -	
C318	1-105-683-12	0.068 μ F	mylar	C371	1-101-884	56pF	ceramic
C319	1-103-613	330pF	styrol	C372	1-121-186	1,000 μ F 16V	electrolytic
C320	1-103-627	1,200pF	styrol	C373	1-105-677-12	0.022 μ F	mylar
C321		- discarded -		C374	1-105-677-12	0.022 μ F	mylar
C322	1-103-614	360pF	styrol	C375	1-101-924	0.02 μ F	ceramic
C323	1-101-959	10pF	ceramic	C376	1-101-924	0.02 μ F	ceramic
C324	1-103-605	150pF	styrol	C377	1-101-924	0.02 μ F	ceramic
C325	1-103-625	1,000pF	styrol	C378	1-101-924	0.02 μ F	ceramic
C326	1-105-677-12	0.022 μ F	mylar	C379	1-101-861	15pF	ceramic
C327	1-105-673-12	0.01 μ F	mylar	C380		- discarded -	
C328	1-105-677-12	0.022 μ F	mylar	C381	1-121-438	1 μ F 12V	electrolytic
C329	1-121-468	10 μ F 6.3V	electrolytic	C401		- discarded -	
C330	1-105-677-12	0.022 μ F	mylar	C402	1-105-685-12	0.1 μ F	mylar
C331	1-105-677-12	0.022 μ F	mylar	C403	1-121-726	0.47 μ F 10V	electrolytic
C332	1-105-677-12	0.022 μ F	mylar	C404	1-105-669-12	0.0047 μ F	mylar
C333		- discarded -		C405		- discarded -	
C334		- discarded -		C406	1-105-689-12	0.22 μ F	mylar
C335	1-101-867	24pF	ceramic	C407	1-105-673-12	0.01 μ F	mylar
C336	1-105-677-12	0.022 μ F	mylar	C408		- discarded -	
C337	1-121-347	10 μ F 16V	electrolytic	C409	1-121-726	0.47 μ F 10V	electrolytic
C338	1-105-677-12	0.022 μ F	mylar	C410	1-121-426	470 μ F 16V	electrolytic
C339	1-103-605	150pF	styrol	C411		- discarded -	
C340	1-101-880	47pF	ceramic	C412	1-107-138	200pF	silvered mica
C341	1-105-677-12	0.022 μ F	mylar	C413	1-105-669-12	0.0047 μ F	mylar
C342	1-101-872	33pF	ceramic	C414	1-121-420	220 μ F 6.3V	electrolytic
C343	1-105-677-12	0.022 μ F	mylar	C415	1-121-415	100 μ F 16V	electrolytic
C344	1-105-677-12	0.022 μ F	mylar	C416	1-121-426	470 μ F 16V	electrolytic
C345	1-101-187	3pF	ceramic	C417		- discarded -	
C346		- discarded -		C418	1-105-677-12	0.022 μ F	mylar
C347	1-105-677-12	0.022 μ F	mylar	C419	1-105-673-12	0.01 μ F	mylar
C348	1-101-864	20pF	ceramic	C420	1-105-677-12	0.022 μ F	mylar
C349		- discarded -		C421	1-105-677-12	0.022 μ F	mylar
C350	1-105-677-12	0.022 μ F	mylar	C422	1-105-661-12	0.001 μ F	mylar
C351		- discarded -		C501	1-115-071	0.0047 μ F 600V	paper
C352		- discarded -		C502	1-115-071	0.0047 μ F 600V	paper
C353	1-105-677-12	0.022 μ F	mylar	C503	1-121-186	1,000 μ F 16V	electrolytic
C354	1-105-677-12	0.022 μ F	mylar	C601	1-121-413	100 μ F 6.3V	electrolytic
C355	1-105-673-12	0.01 μ F	mylar	C01	1-105-839-12	0.033 μ F	mylar
C356	1-103-608	200pF	styrol	C02	1-105-673-12	0.015 μ F	mylar
C357	1-103-608	200pF	styrol	C03	1-105-839-12	0.033 μ F	mylar
C358	1-121-468	10 μ F 6.3V	electrolytic	C04	1-102-764	100pF	ceramic
C359	1-105-677-12	0.022 μ F	mylar	C05	1-103-651	100pF	styrol
C360	1-105-681-12	0.0047 μ F	mylar	CV1-1~			
C361	1-105-673-12	0.01 μ F	mylar	CV1-4	1-151-158-12	capacitor, fm tuning, 4 gang	
C362	1-105-673-12	0.01 μ F	mylar				

<u>Ref. No.</u>	<u>Part No.</u>	<u>Description</u>
CV201-1	1-151-214	capacitor, sw tuning, 2 gang
CV201-2		
CV301-1	1-151-182-13S	capacitor, lw/mw/sw1 tuning, 3 gang
CV301-2		
CV301-3		
CT1-1~ CT1-4	1-141-086	capacitor, fm trimmer, 4 gang
CT201	1-141-078	capacitor, sw trimmer (16pF)
CT202	1-141-078	capacitor, sw trimmer (16pF)
CT203	1-141-078	capacitor, sw trimmer (16pF)
CT204	1-141-078	capacitor, sw trimmer (16pF)
CT205	1-141-078	capacitor, sw trimmer (16pF)
CT206	1-141-078	capacitor, sw trimmer (16pF)
CT207	1-141-078	capacitor, sw trimmer (16pF)
CT208	1-141-078	capacitor, sw trimmer (16pF)
CT209	1-141-078	capacitor, sw trimmer (16pF)
CT210	1-141-078	capacitor, sw trimmer (16pF)
CT211	1-141-078	capacitor, sw trimmer (16pF)
CT212	1-141-078	capacitor, sw trimmer (16pF)
CT213	1-141-078	capacitor, sw trimmer (16pF)
CT214	1-141-078	capacitor, sw trimmer (16pF)
CT215	1-141-078	capacitor, sw trimmer (16pF)
CT216	1-141-078	capacitor, sw trimmer (16pF)
CT217	1-141-078	capacitor, sw trimmer (16pF)
CT218	1-141-078	capacitor, sw trimmer (16pF)
CT301-1	1-141-015-12	capacitor, a-m trimmer, 3 gang
CT301-2		
CT301-3		
CT302	1-141-135	capacitor, trimmer (30pF)
CT303	1-141-135	capacitor, trimmer (30pF)
CT304	1-141-135	capacitor, trimmer (30pF)
CT305	1-141-135	capacitor, trimmer (30pF)
CT306	1-141-135	capacitor, trimmer (30pF)
CT307	1-141-135	capacitor, trimmer (30pF)
CT308	1-141-135	capacitor, trimmer (30pF)
CT309	1-141-135	capacitor, trimmer (30pF)
CT310	1-141-135	capacitor, trimmer (30pF)

RESISTORS

All resistors are 1/4W ±5% carbon type resistors unless otherwise specified.

R101	1-208-027	560Ω	1/16W	ceramic
R102	1-208-027	560Ω	1/16W	ceramic
R103	1-244-697	10kΩ		
R104	1-244-697	10kΩ		
R105	1-208-045	3.3kΩ	1/16W	ceramic
R106	1-208-145	100kΩ	1/16W	ceramic
R107	1-208-145	100kΩ	1/16W	ceramic
R108	1-208-088	200kΩ	1/16W	ceramic
R109	1-208-027	560Ω	1/16W	ceramic
R110	1-208-033	1kΩ	1/16W	ceramic
R201	1-244-653	150Ω		

<u>Ref. No.</u>	<u>Part No.</u>	<u>Description</u>
R202	1-244-656	200Ω
R203	1-210-372	3kΩ 1/16W micro
R204	1-209-767	2kΩ 1/16W micro
R205	1-209-766	1.5kΩ 1/16W micro
R206	1-209-772	4.3kΩ 1/16W micro
R207	1-209-878	1.8kΩ 1/16W micro
R208	1-210-108	820Ω 1/16W micro
R209	1-209-770	2.7kΩ 1/16W micro
R210	1-209-767	2kΩ 1/16W micro
R211	1-209-766	1.5kΩ 1/16W micro
R212	1-221-638-12	100kΩ adjustable
R213	1-244-704	20kΩ
R214	1-244-657	220Ω
R215	1-244-688	4.3kΩ
R216	1-244-690	5.1kΩ
R217	1-244-661	330Ω
R218	1-244-669	680Ω
R219	1-244-642	51Ω
R301	1-240-505	22kΩ
R302	1-240-490	5.1kΩ
R303	1-240-473	1kΩ
R304	1-240-473	1kΩ
R305	1-240-464	430Ω
R306	1-240-510	36kΩ
R307	1-240-442	51Ω
R308	1-240-508	30kΩ
R309	1-240-473	1kΩ
R310	1-240-473	1kΩ
R311	1-240-456	200Ω
R312		- discarded -
R313	1-240-499	12kΩ
R314	1-240-527	180kΩ
R315	1-240-473	1kΩ
R316	1-240-449	100Ω
R317	1-240-473	1kΩ
R318	1-240-473	1kΩ
R319	1-240-473	1kΩ
R320	1-240-465	470Ω
R321	1-240-465	470Ω
R322	1-240-473	1kΩ
R323	1-240-484	3kΩ
R324	1-240-471	820Ω
R325	1-240-466	510Ω
R326	1-240-482	2.4kΩ
R327	1-240-480	2kΩ
R328	1-240-525	150kΩ
R329	1-240-477	1.5kΩ
R330		- discarded -
R331	1-240-512	43kΩ
R332	1-240-522	110kΩ
R333	1-240-442	51Ω
R334	1-240-497	10kΩ
R335	1-240-465	470Ω

<u>Ref. No.</u>	<u>Part No.</u>	<u>Description</u>	<u>Ref. No.</u>	<u>Part No.</u>	<u>Description</u>
R336	1-240-473	1 k Ω	R372	1-240-490	5.1 k Ω
R337	1-240-519	82 k Ω	R373	1-240-442	51 Ω
× R338	1-240-520	91 k Ω	R374	1-240-517	68 k Ω
	1-240-521	100 k Ω	R375	1-240-442	51 Ω
	1-240-522	110 k Ω	R376	1-240-490	5.1 k Ω
	1-240-523	120 k Ω	R377	1-240-473	1 k Ω
	1-240-524	130 k Ω	R401		– discarded –
	1-240-525	150 k Ω	R402	1-240-538	510 k Ω
R339	1-240-442	51 Ω	R403	1-240-485	3.3 k Ω
R340	1-240-460	300 Ω	R404	1-240-461	330 Ω
R341	1-240-483	2.7 k Ω	R405		– discarded –
× R342	1-240-473	1 k Ω	R406	1-240-512	43 k Ω
	1-240-475	1.2 k Ω	R407	1-240-483	6.8 k Ω
	1-240-477	1.5 k Ω	R408	1-240-496	9.1 k Ω
	1-240-479	1.8 k Ω	R409		– discarded –
	1-240-480	2.0 k Ω	R410		– discarded –
× R343	1-240-470	750 Ω	R411	1-240-538	510 k Ω
	1-240-471	820 Ω	R412	1-240-484	3 k Ω
	1-240-472	910 Ω	R413	1-240-486	3.6 k Ω
	1-240-473	1 k Ω	R414	1-240-445	68 Ω
	1-240-475	1.2 k Ω	R415		– discarded –
R344	1-240-499	12 k Ω	R416	1-242-680	2 k Ω
R345	1-240-465	470 Ω	R417	1-240-459	270 Ω
R346	1-240-501	15 k Ω	R418	1-240-427	12 Ω
R347	1-240-510	36 k Ω	R419	1-240-443	56 Ω
R348	1-240-468	620 Ω	R420	1-240-455	180 Ω
R349	1-240-497	10 k Ω	R421	1-240-471	820 Ω
R350	1-240-457	220 Ω	R422	1-240-455	180 Ω
R351	1-240-449	100 Ω	R423	1-240-471	820 Ω
R352	1-240-442	51 Ω	R424	1-210-154	1.5 Ω 1W carbon
R353	1-240-456	200 Ω	R425	1-210-154	1.5 Ω 1W carbon
R354	1-240-508	30 k Ω	R426		– discarded –
R355	1-240-501	15 k Ω	R427	1-209-154	33 Ω 1W carbon
R356	1-240-497	10 k Ω	R428	1-240-447	82 Ω
R357	1-240-457	220 Ω	R501	1-244-847	82 Ω ½W carbon
R358	1-240-465	470 Ω	R502	1-240-417	4.7 Ω
R359	1-240-473	1 k Ω	R503	1-202-645	1 M Ω ½W composition
R360	1-240-494	7.5 k Ω	R504	1-244-847	82 Ω ½W carbon
R361	1-240-494	7.5 k Ω	RV01		
R362	1-240-473	1 k Ω	RV03	1-222-504	mgc and bfo control, 20k Ω and 10k Ω
R363	1-240-473	1 k Ω	RV02	1-221-634	1 k Ω variable
R364	1-240-531	270 k Ω	RV601	1-222-218	volume control, 50 k Ω
R365		– discarded –	RV602	1-222-216	tone control, 50 k Ω
R366	1-240-473	1 k Ω	R01	1-244-668	620 Ω
R367	1-240-466	510 Ω	R02	1-244-678	1.6 k Ω
R368	1-240-487	3.9 k Ω	R03	1-244-669	680 Ω
R369	1-240-467	560 Ω	R04	1-244-663	390 Ω
R370	1-240-448	91 k Ω	R05	1-244-654	160 Ω
× R371	1-240-466	510 Ω	R06	1-244-710	36 k Ω
	1-240-467	560 Ω	R601	1-240-492-11	6.2 k Ω
	1-240-468	620 Ω			
	1-240-469	680 Ω			
	1-240-470	750 Ω			

MISCELLANEOUS

8-981-365-10 fm front end block, FMC-094W1

× to be selected.

<u>Ref. No.</u>	<u>Part No.</u>	<u>Description</u>
	8-981-367-51	sw front end block, SWC-021D2
	8-981-407-12	bfo block, BFO-2A
	1-539-252-14	printed circuit board, cp/i-f
	1-539-253-12	printed circuit board, af
	1-581-103-11	printed circuit board, ac power supply
	1-581-104-11	printed circuit board, dc power supply
TEL ANT	1-501-129	antenna, telescopic
S201 ~)		SW2-SW10 band selector, assembled
S205		in sw front end
S301 ~)		
S305	1-514-670	5 key switch, band selector
S306	1-514-594	push switch, selectivity
S501	1-514-503	lever switch, power
S502	1-514-269	leaf switch, pilot lamp
S503		ac dc selector, assembled in power supply connector
S504	1-514-421-31	lever seesaw switch, AFC

<u>Ref. No.</u>	<u>Part No.</u>	<u>Description</u>
J501	1-509-362	connector, ac or ext. dc power supply
J601	1-507-169-13	jack, record out
602	1-507-169-13	jack, earphone
	1-507-901-12	nut, earphone jack
SP601	1-502-241-21	speaker, 4 Ω
PL601	1-518-115-11	pilot lamp
PL602	1-518-115-11	pilot lamp
PL603	1-518-115-11	pilot lamp
MT-1	1-520-095-12	tuning meter
VSS01	1-526-188-21	voltage selector (General Export Model only)
	1-536-178	plate, lug
	1-536-312	lug terminal
	1-536-179	plate, lug
	1-534-519-11	ac cord with plug (USA model)
	1-534-518-11	ac cord with plug (General Export model)
	1-534-660-11	ac cord with Euro-plug
	1-534-519-21	ac cord with plug (Canada model)